



(12) **United States Patent**  
**Sia**

(10) **Patent No.:** **US 10,808,679 B2**  
(45) **Date of Patent:** **Oct. 20, 2020**

(54) **DRONE MOUNTED WIND TURBINE-GENERATOR SYSTEM**

(56) **References Cited**

U.S. PATENT DOCUMENTS

(71) Applicant: **Yik Hei Sia**, Johor Bahru (MY)  
(72) Inventor: **Yik Hei Sia**, Johor Bahru (MY)  
(\* ) Notice: Subject to any disclaimer, the term of this patent is extended or adjusted under 35 U.S.C. 154(b) by 0 days.

2,388,478	A *	11/1945	Garber	.....	A63H 27/002
					244/155 A
4,124,182	A *	11/1978	Loeb	.....	F03D 5/00
					244/153 R
4,641,797	A *	2/1987	Stolk	.....	A63H 27/08
					244/153 R
4,892,272	A *	1/1990	Hadzicki	.....	B63H 8/16
					244/153 R
5,435,259	A *	7/1995	Labrador	.....	B01D 61/10
					114/39.31
6,498,402	B2 *	12/2002	Saiz	.....	F03D 5/02
					290/54
7,188,808	B1 *	3/2007	Olson	.....	F03D 5/00
					244/153 R
8,350,403	B2 *	1/2013	Carroll	.....	B65H 75/4402
					290/55
8,446,034	B1 *	5/2013	Stevens	.....	F03D 5/00
					290/44
8,539,746	B2 *	9/2013	Ippolito	.....	C02F 1/286
					57/200
8,602,363	B2 *	12/2013	Larson	.....	F03D 9/25
					244/155 A
8,963,362	B2 *	2/2015	Sia	.....	F03D 5/00
					290/55
9,234,501	B2 *	1/2016	Sia	.....	F03B 17/06
9,239,041	B2 *	1/2016	Goldstein	.....	B64C 39/022
9,447,775	B2 *	9/2016	Sia	.....	F03D 5/02
9,698,652	B2 *	7/2017	Sia	.....	F03D 5/00
9,745,951	B1 *	8/2017	Doyle	.....	F03B 17/061
9,797,379	B2 *	10/2017	Ori	.....	F03D 1/025
10,113,534	B2 *	10/2018	Sia	.....	F03D 9/008

(21) Appl. No.: **16/544,831**

(22) Filed: **Aug. 19, 2019**

(65) **Prior Publication Data**  
US 2020/0056584 A1 Feb. 20, 2020

(30) **Foreign Application Priority Data**  
Aug. 20, 2018 (SG) ..... 10201807027W  
Aug. 14, 2019 (SG) ..... 10201907453Y

(51) **Int. Cl.**  
**F03D 9/00** (2016.01)  
**H02P 9/04** (2006.01)  
**F03D 7/02** (2006.01)  
**F03D 1/00** (2006.01)  
**B64C 39/02** (2006.01)

(52) **U.S. Cl.**  
CPC ..... **F03D 7/0204** (2013.01); **B64C 39/022** (2013.01); **F03D 1/00** (2013.01); **F05B 2240/921** (2013.01)

(58) **Field of Classification Search**  
CPC ..... F03D 1/00; F03D 7/0204; B64C 39/022  
See application file for complete search history.

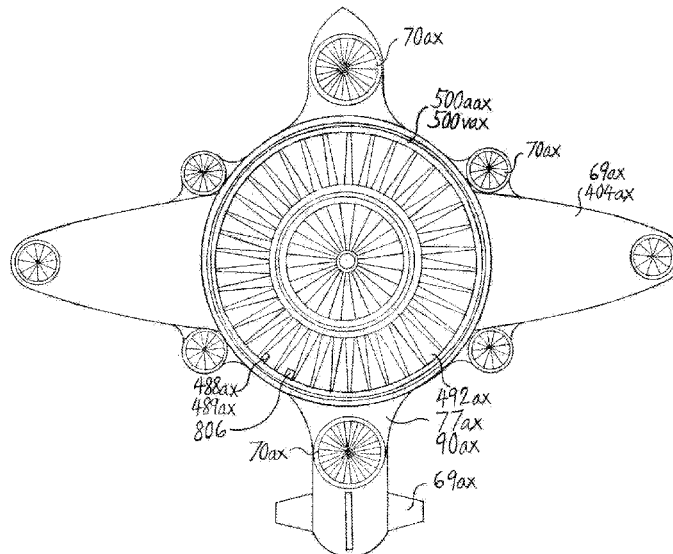
(Continued)

*Primary Examiner* — Tulsidas C Patel  
*Assistant Examiner* — Thomas K Quigley  
(74) *Attorney, Agent, or Firm* — Crockett & Crockett, PC; K. David Crockett, Esq.; Niky Economy Syrengelas, Esq.

(57) **ABSTRACT**

An airborne wind turbine system for generation of power via windbags and waterbags.

**1 Claim, 25 Drawing Sheets**



(56)

**References Cited**

U.S. PATENT DOCUMENTS

10,233,902 B2 \* 3/2019 Sia ..... F03D 9/30  
 10,337,489 B2 \* 7/2019 Wentzel ..... F03B 13/264  
 10,442,524 B1 \* 10/2019 Treat ..... B64C 5/02  
 10,556,709 B1 \* 2/2020 Kimchi ..... B64C 39/024  
 10,590,911 B2 \* 3/2020 Aull ..... B64C 31/06  
 10,619,625 B2 \* 4/2020 Sia ..... F03D 5/02  
 2002/0185570 A1 \* 12/2002 Winner ..... A63H 27/002  
 244/155 A  
 2006/0097114 A1 \* 5/2006 Goodman ..... B64C 31/06  
 244/155 A  
 2007/0250226 A1 \* 10/2007 Wrage ..... B63H 9/069  
 701/21  
 2008/0048453 A1 \* 2/2008 Amick ..... B82Y 30/00  
 290/44  
 2010/0066095 A1 \* 3/2010 Meller ..... F03D 9/25  
 290/55  
 2010/0276941 A1 \* 11/2010 Zhang ..... F03B 17/06  
 290/55

2010/0314886 A1 \* 12/2010 Potter ..... F03D 1/04  
 290/55  
 2011/0101692 A1 \* 5/2011 Bilaniuk ..... B64B 1/20  
 290/44  
 2011/0210559 A1 \* 9/2011 Zanetti ..... F03D 5/06  
 290/55  
 2015/0180186 A1 \* 6/2015 Vander Lind ..... H01R 35/02  
 290/55  
 2015/0184639 A1 \* 7/2015 Goessling ..... F03D 1/02  
 290/44  
 2015/0188367 A1 \* 7/2015 Vander Lind ..... H02K 1/185  
 290/55  
 2015/0298806 A1 \* 10/2015 Vander Lind ..... B63H 9/069  
 518/704  
 2015/0308410 A1 \* 10/2015 Goldstein ..... F01D 13/02  
 290/55  
 2015/0354539 A1 \* 12/2015 Goessling ..... B64F 3/02  
 290/44  
 2015/0375852 A1 \* 12/2015 Hallamasek ..... F03D 7/047  
 244/175  
 2016/0207626 A1 \* 7/2016 Bailey ..... B64C 39/022

\* cited by examiner







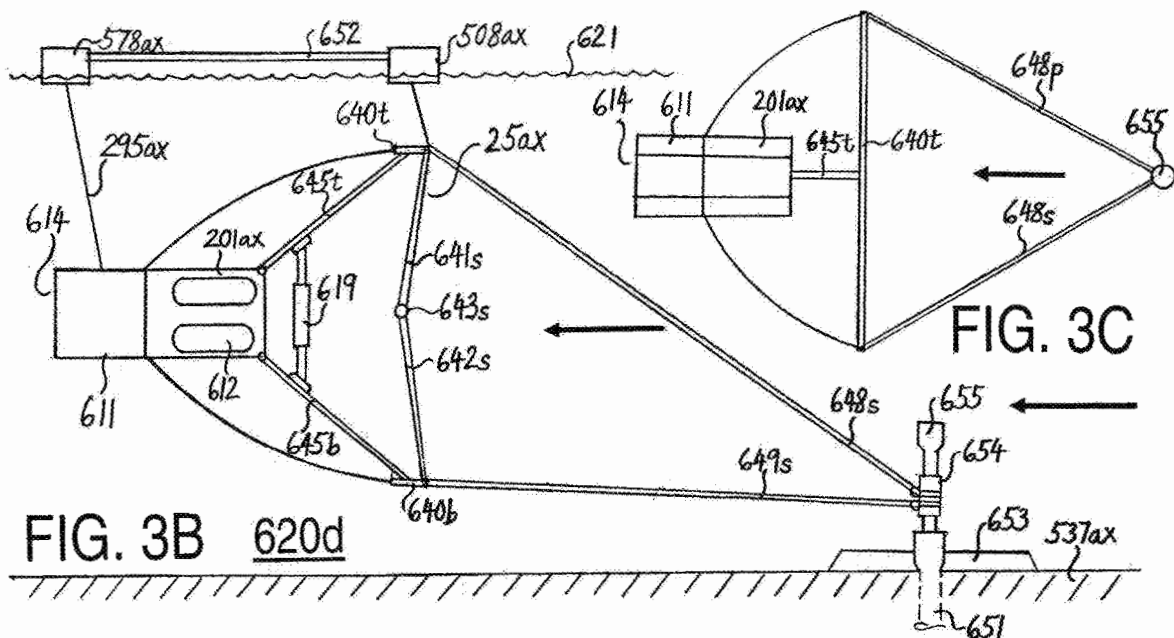


FIG. 3B

FIG. 3C

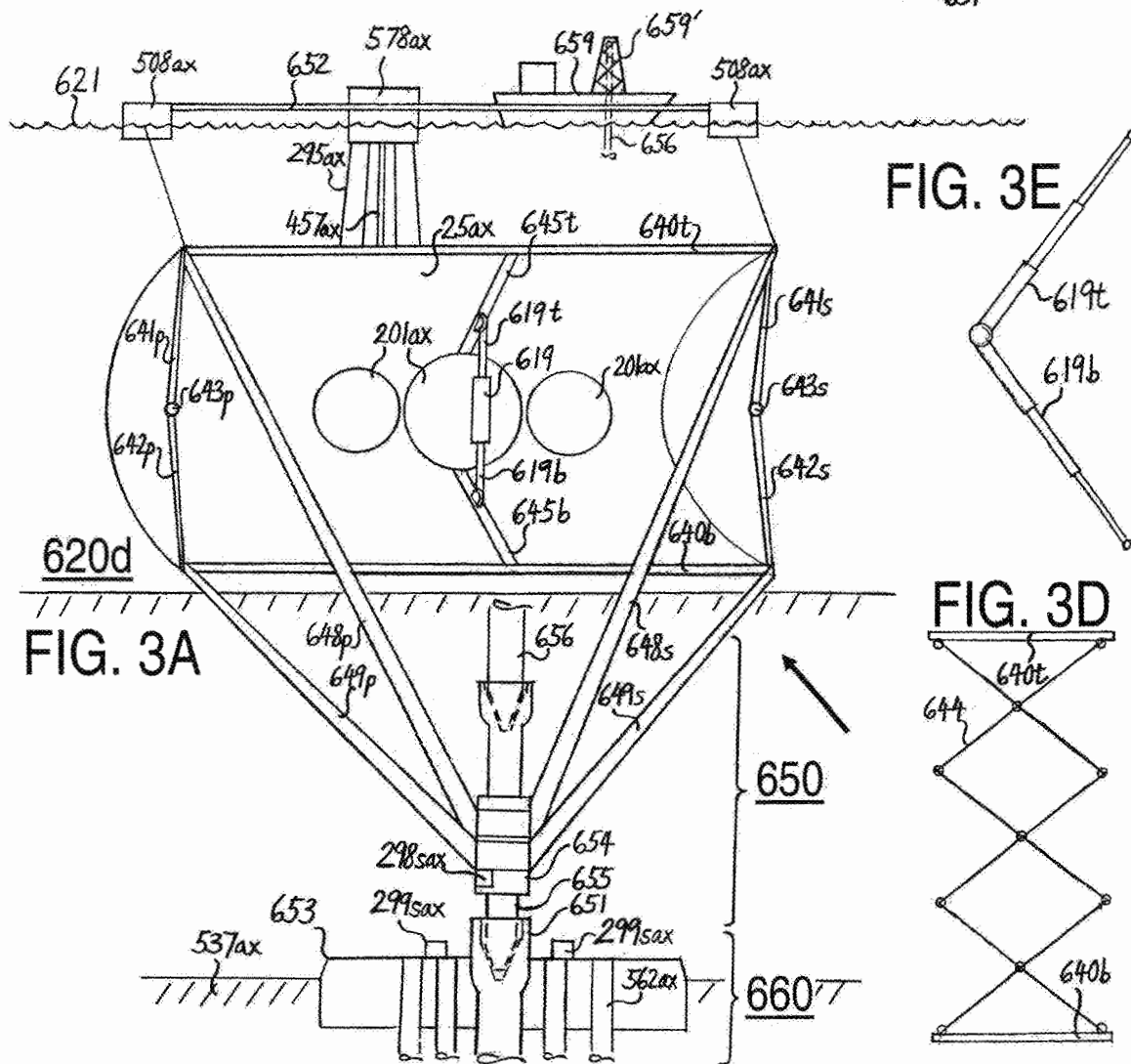


FIG. 3A

FIG. 3E

FIG. 3D

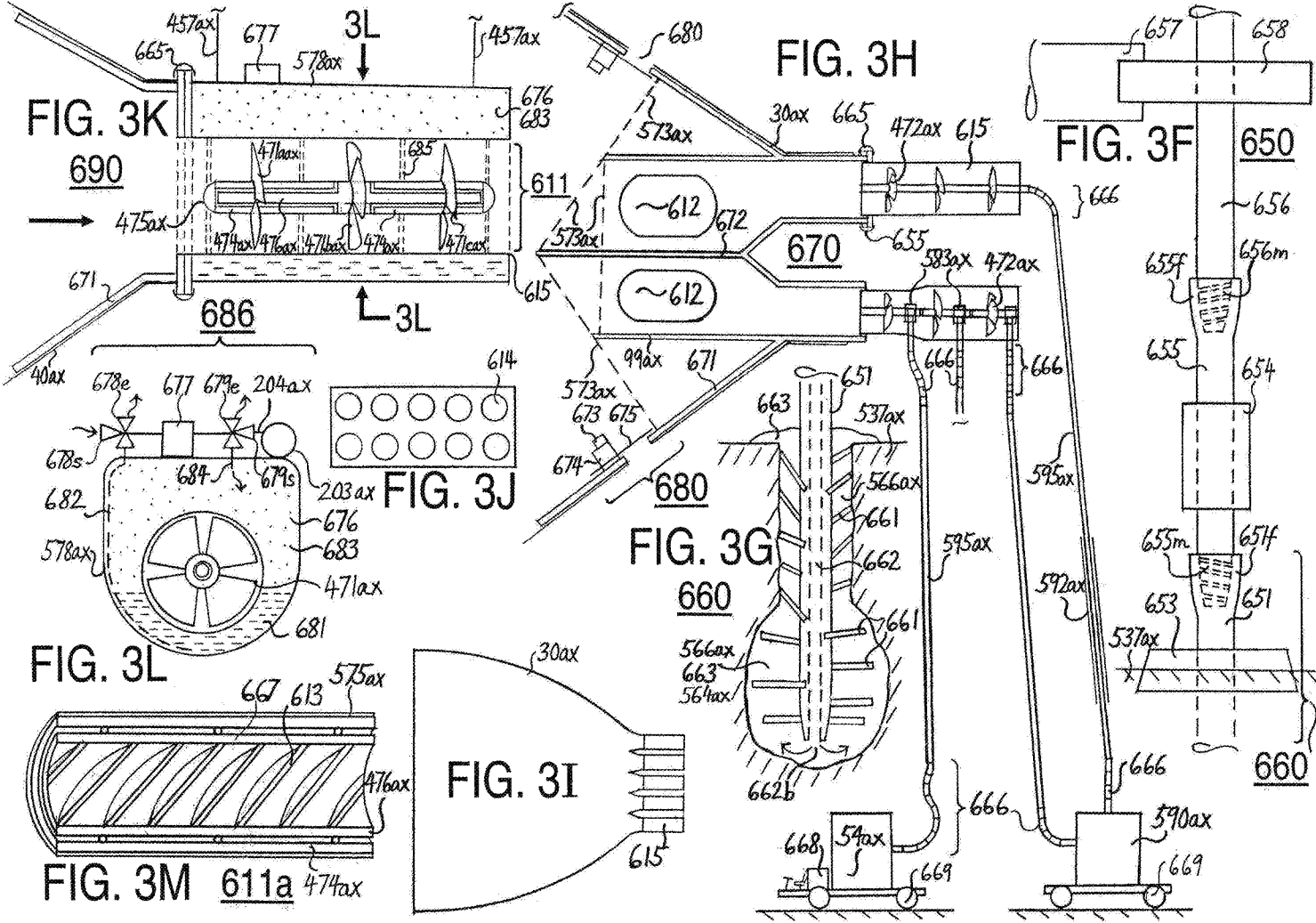
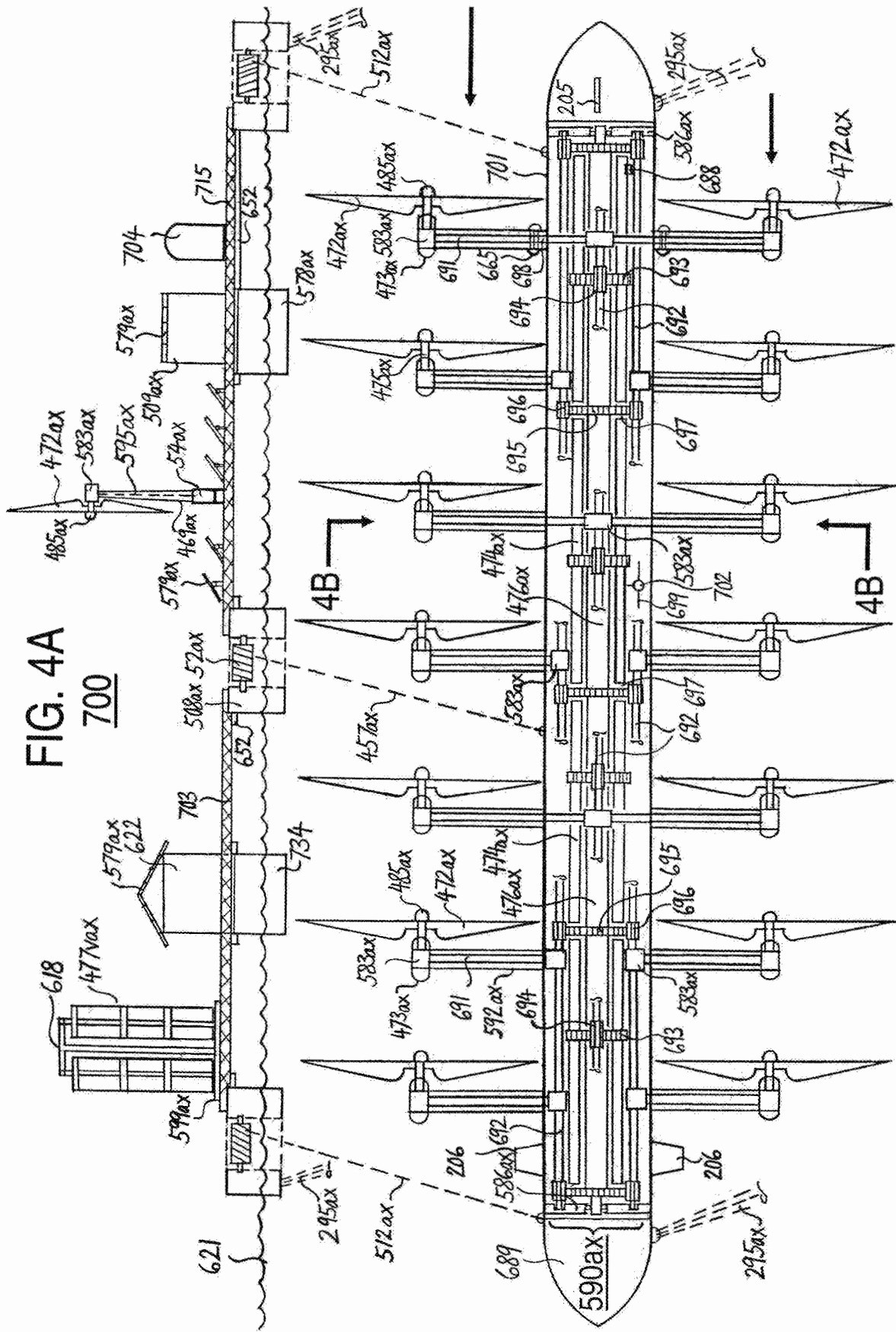
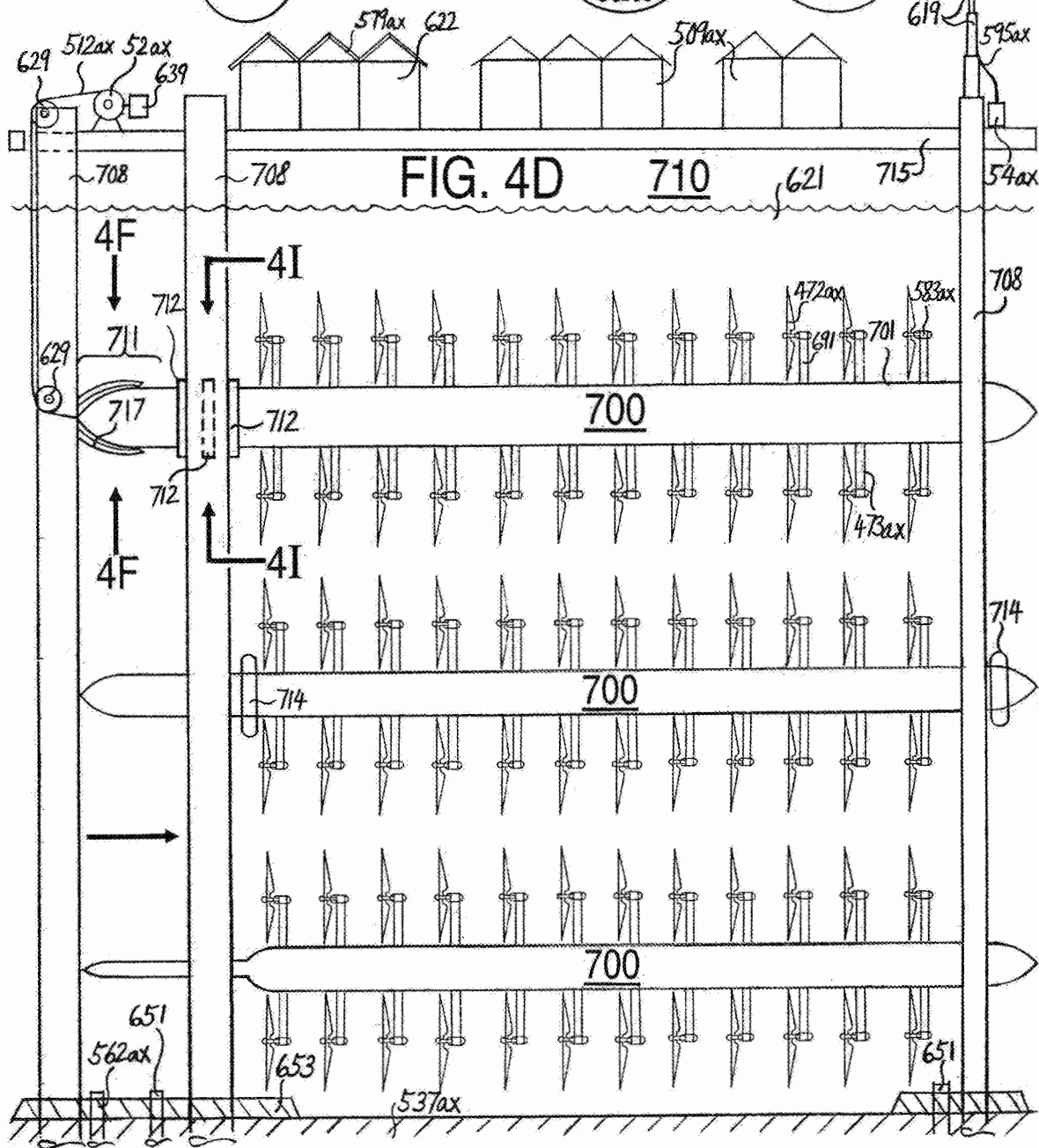
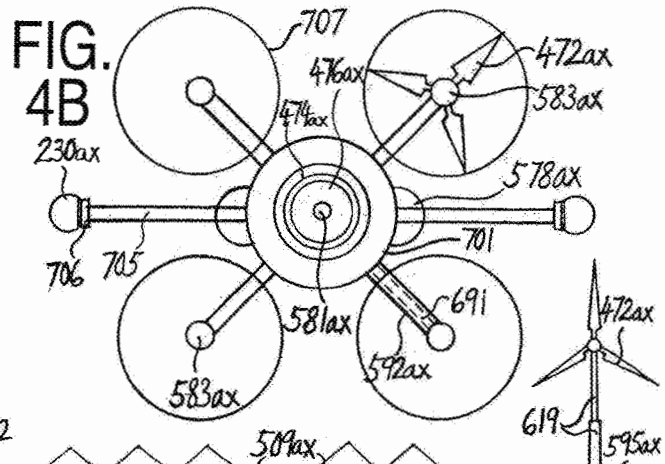
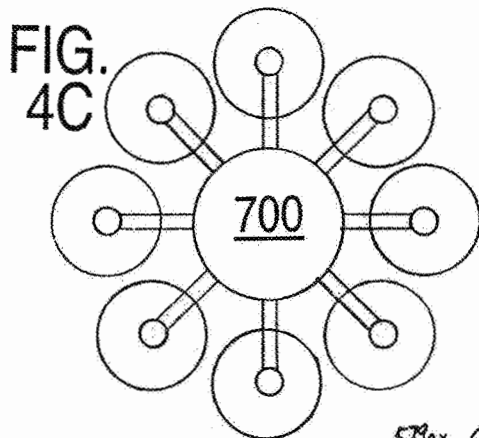
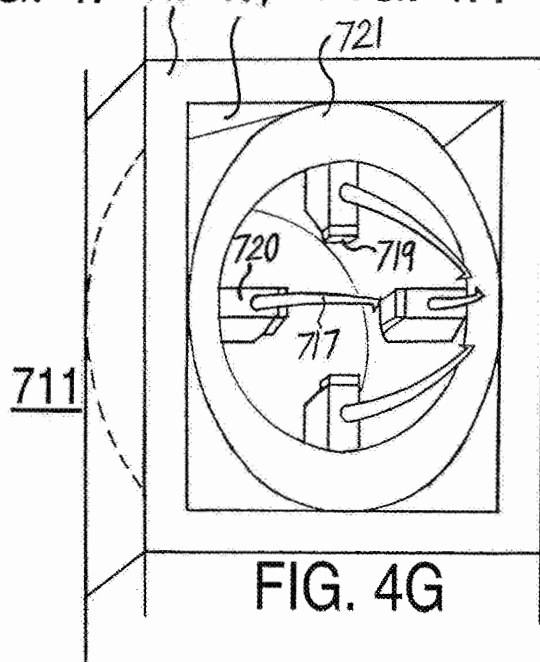
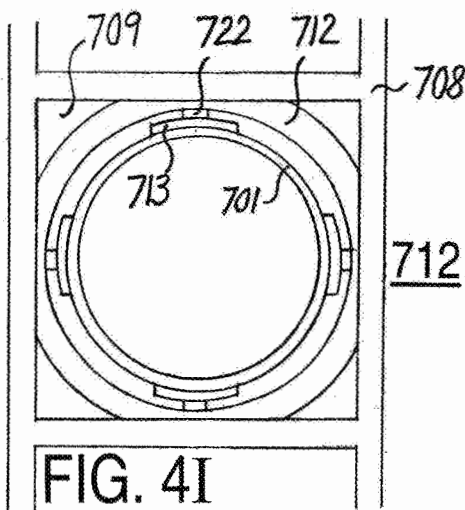
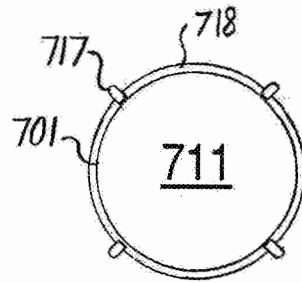
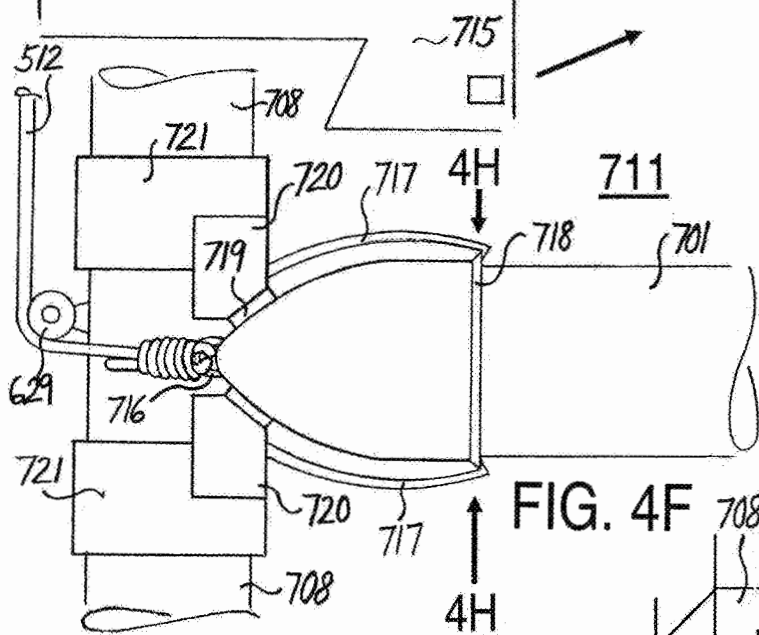
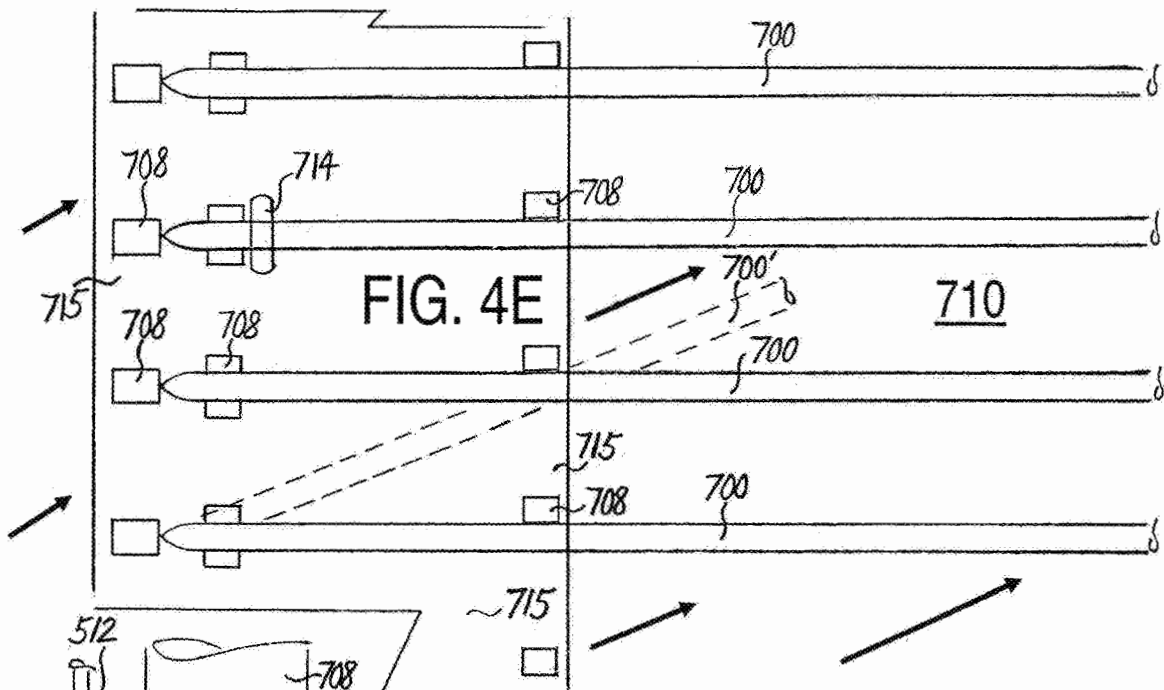
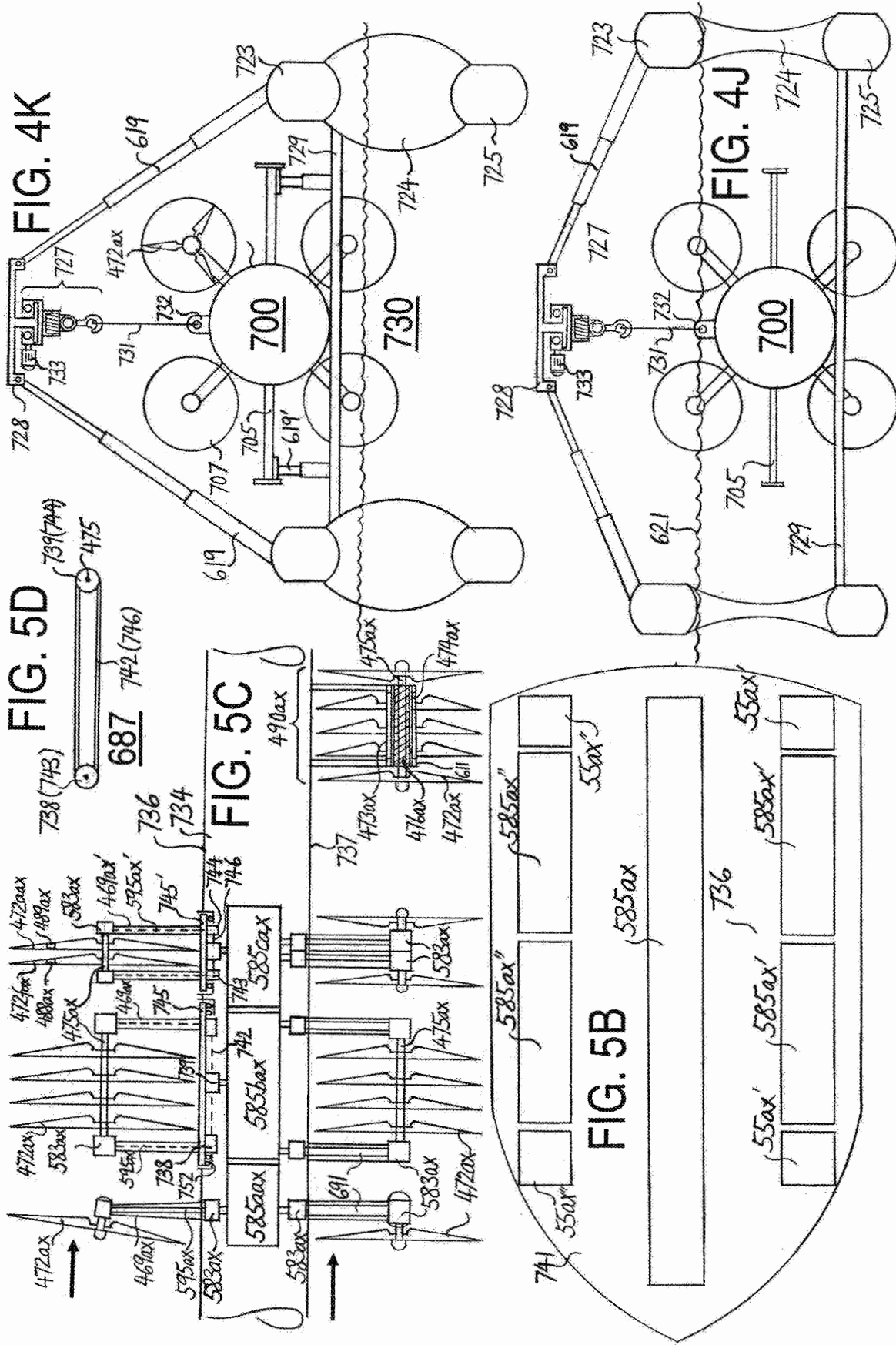


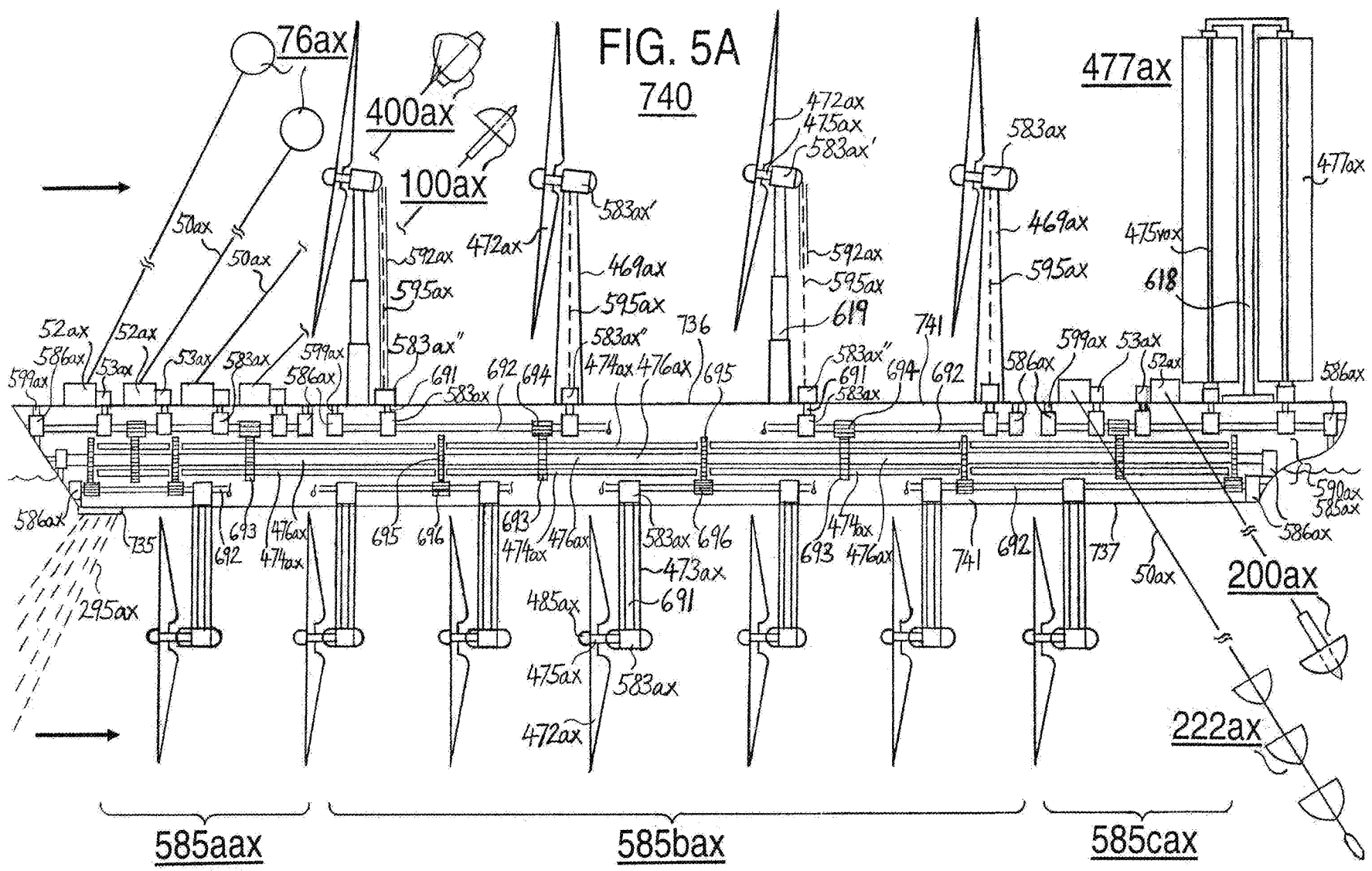
FIG. 4A  
700











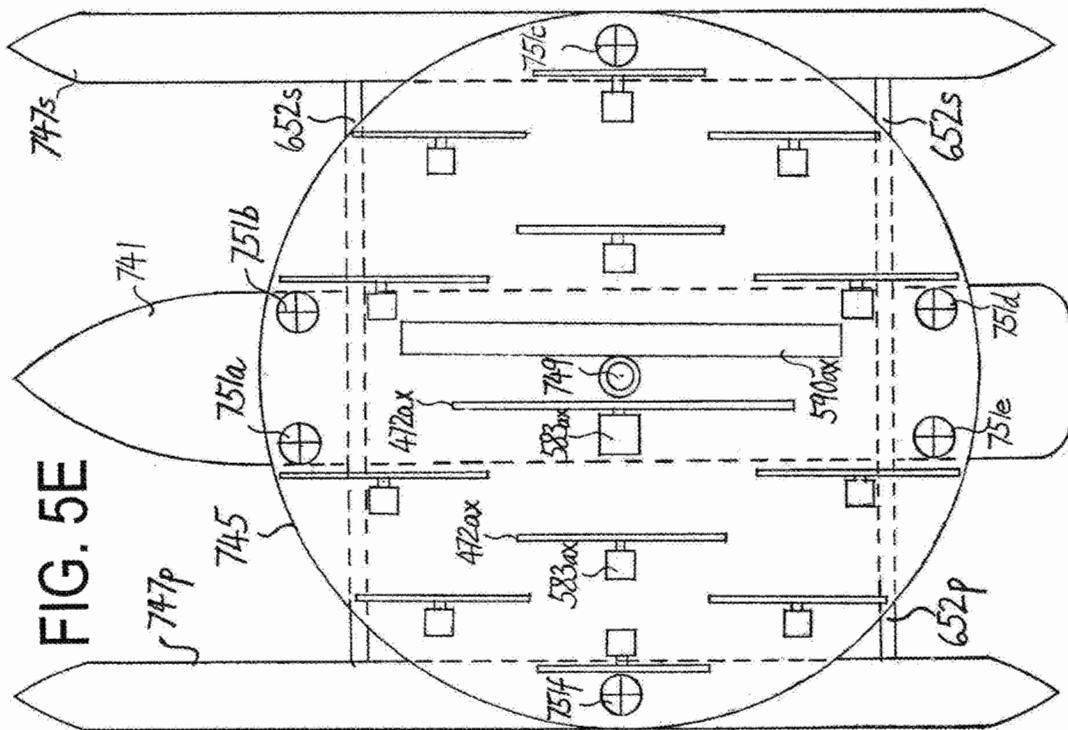


FIG. 5E

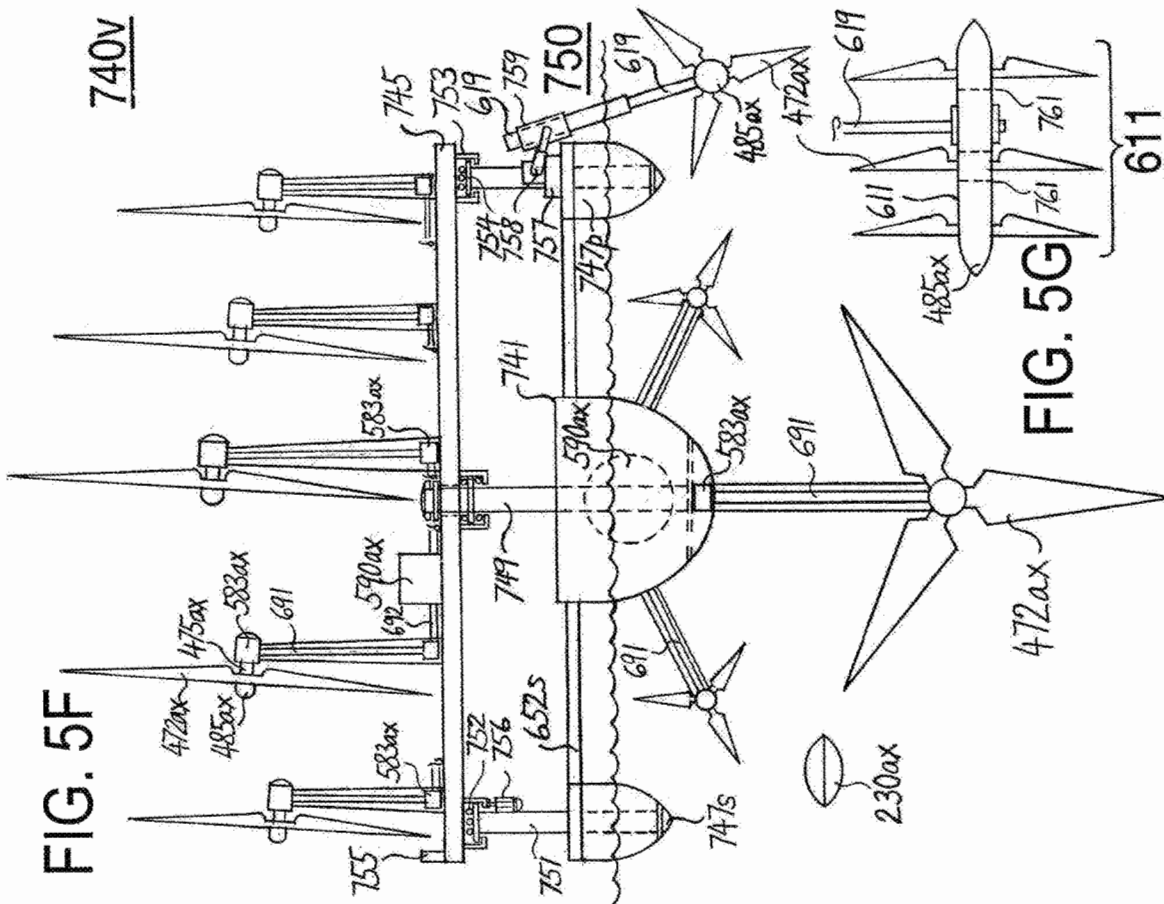


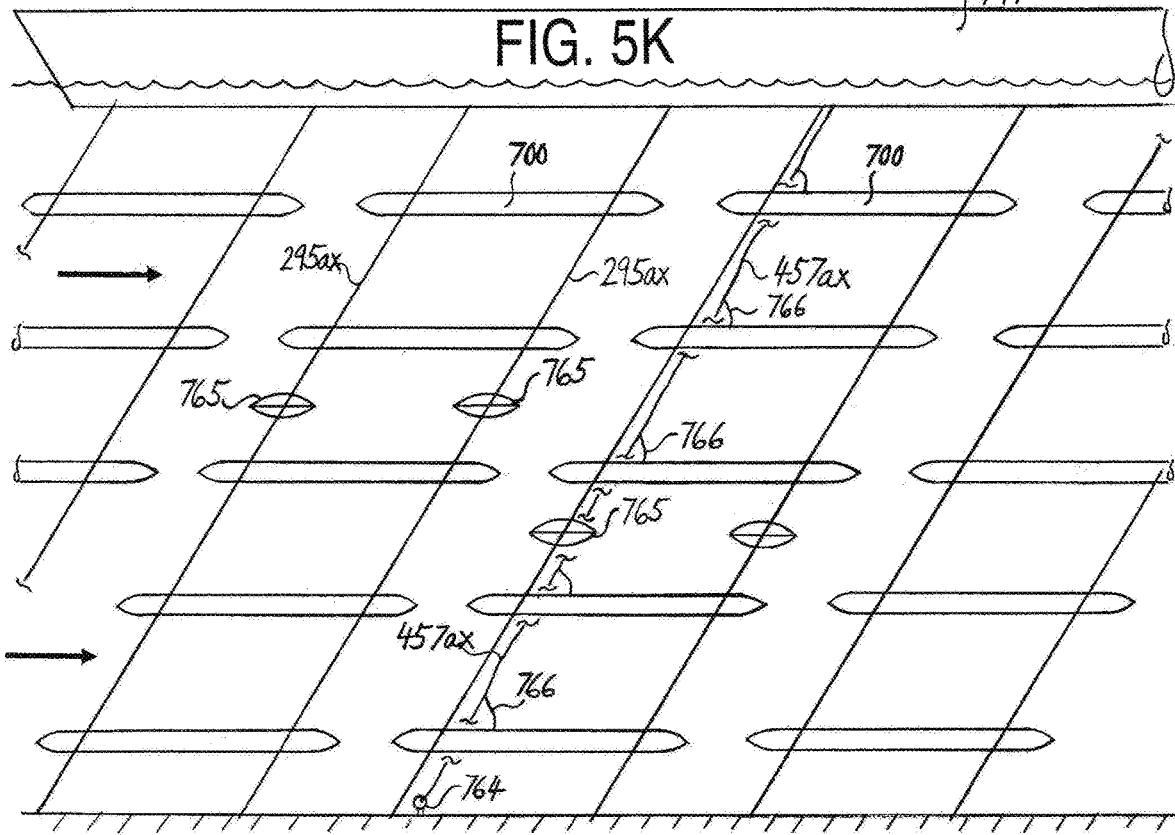
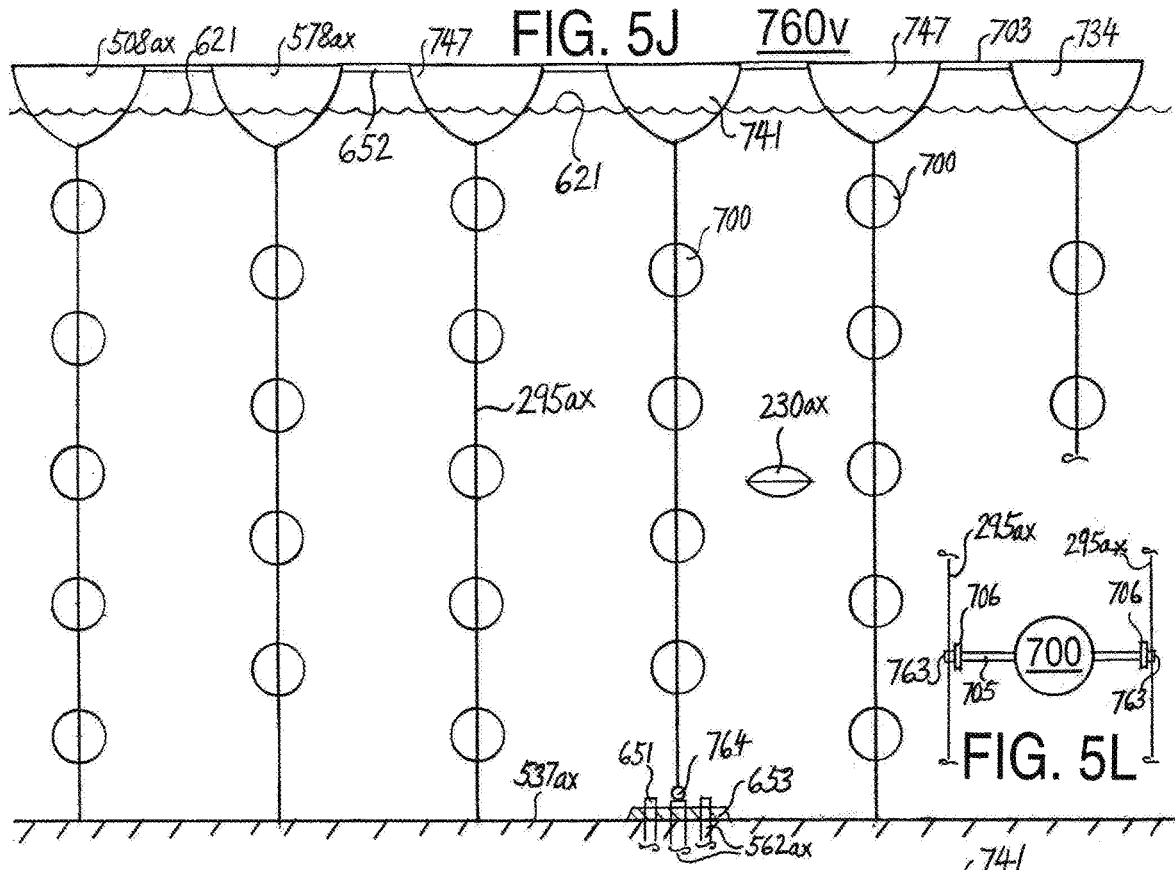
FIG. 5F

FIG. 5G

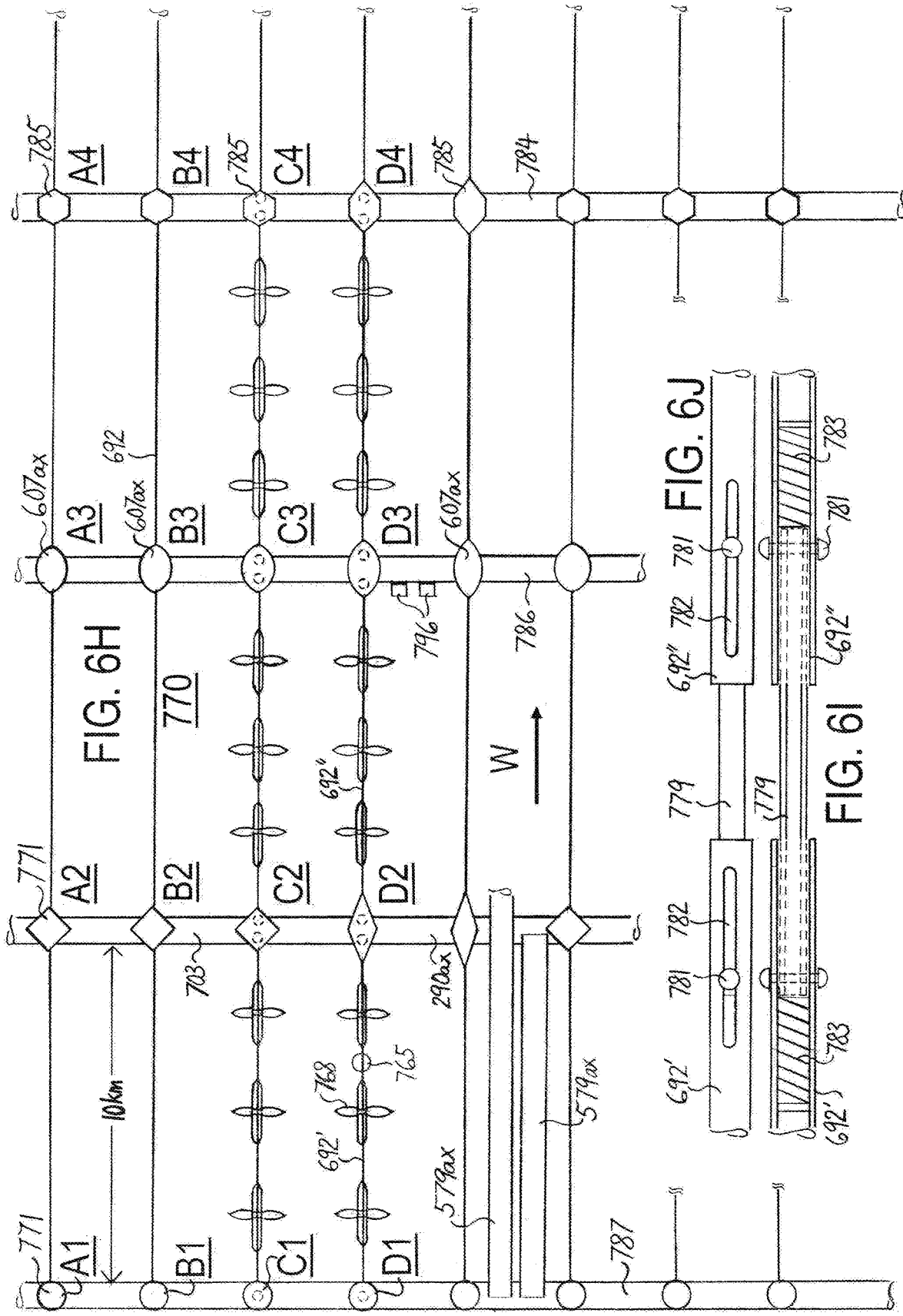
740V





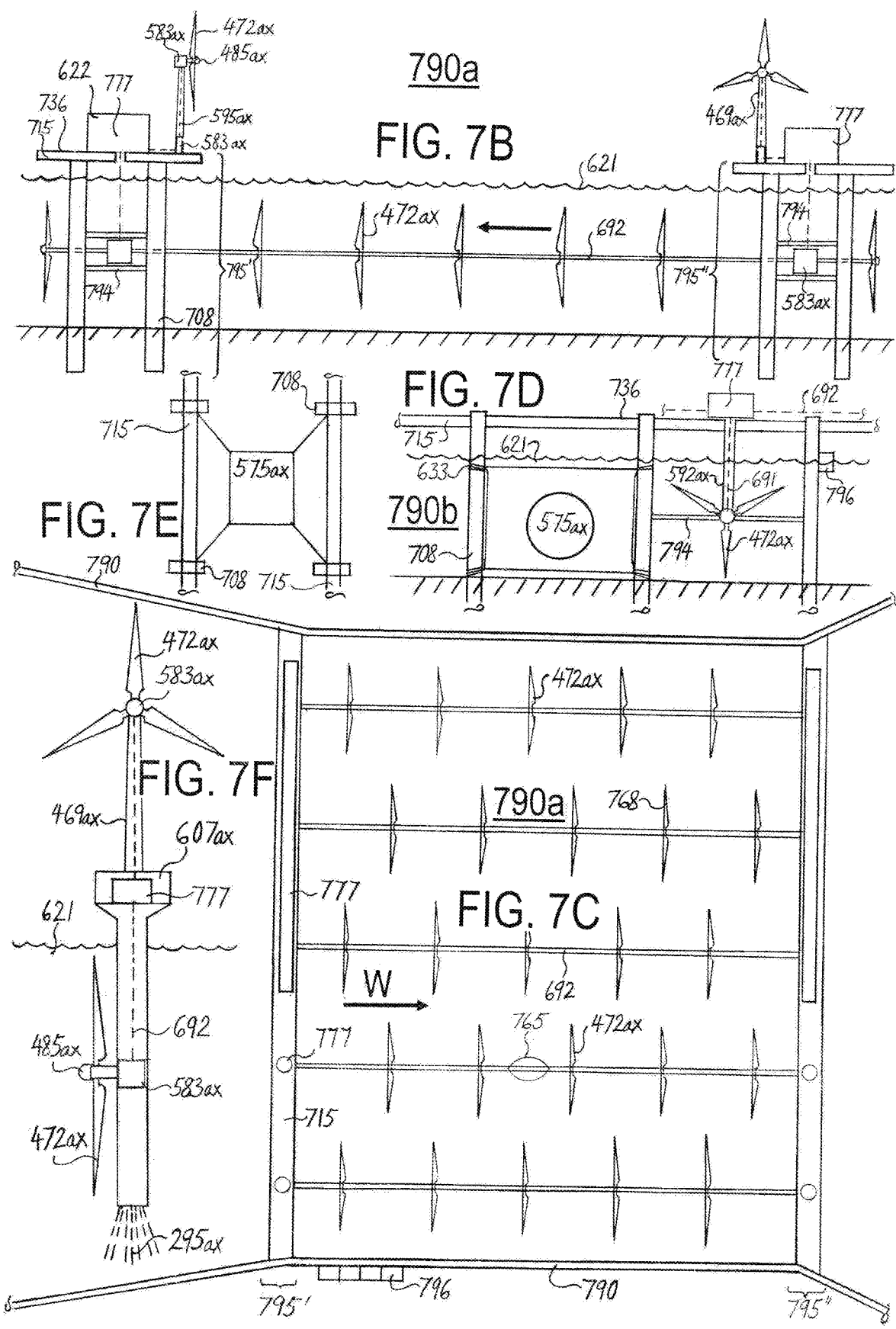






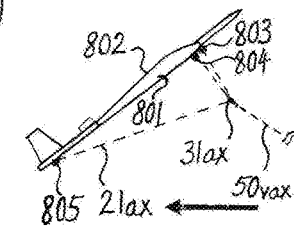
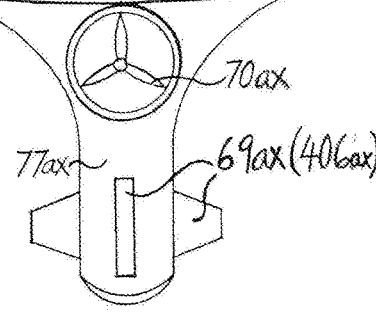
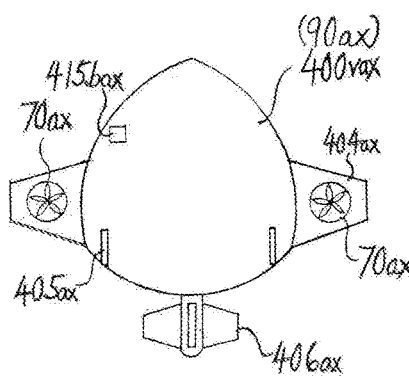
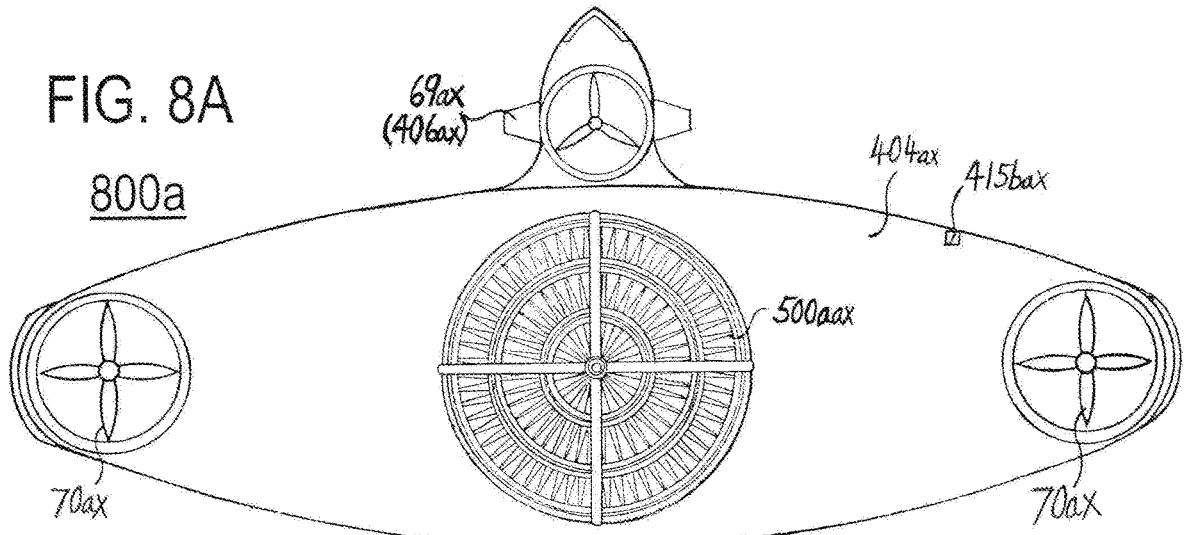










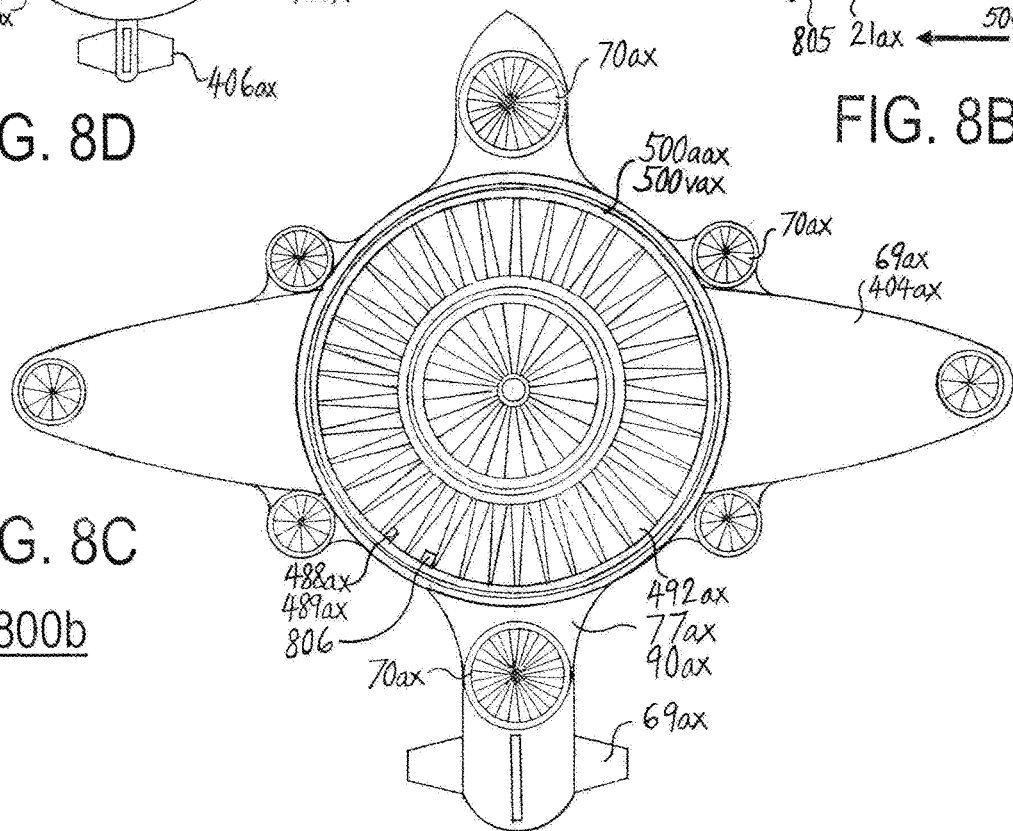


**FIG. 8D**

**FIG. 8B**

**FIG. 8C**

800b



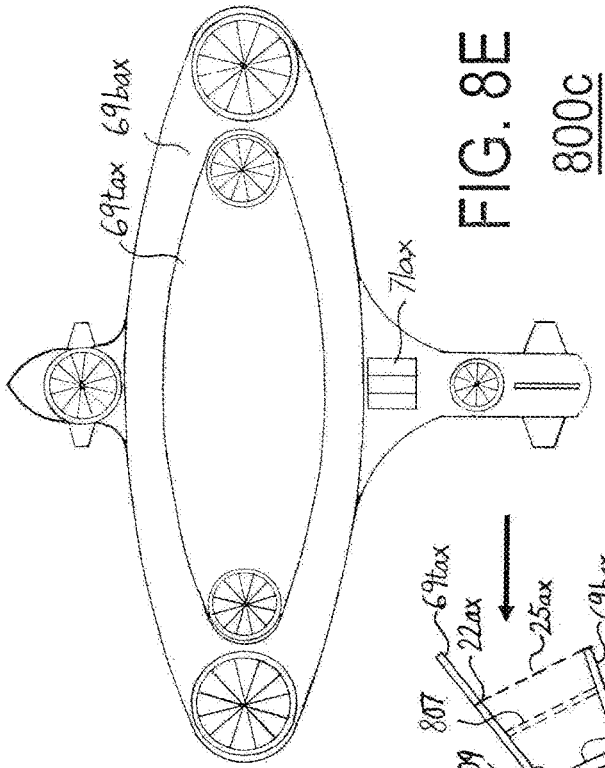


FIG. 8E

800c

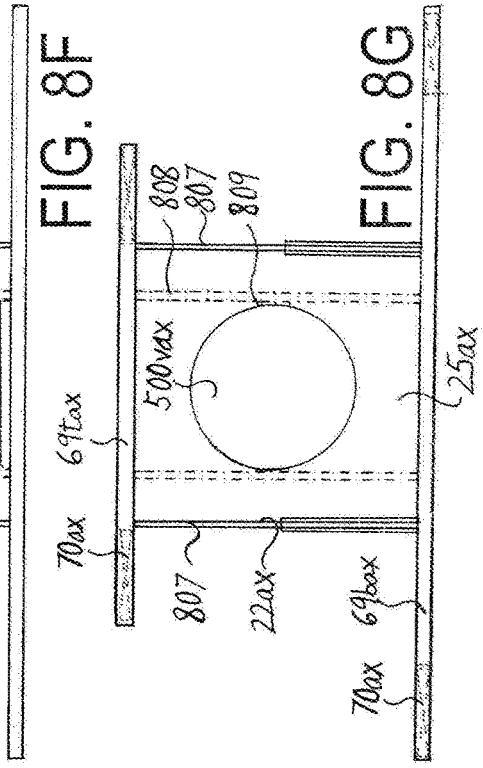


FIG. 8F

FIG. 8G

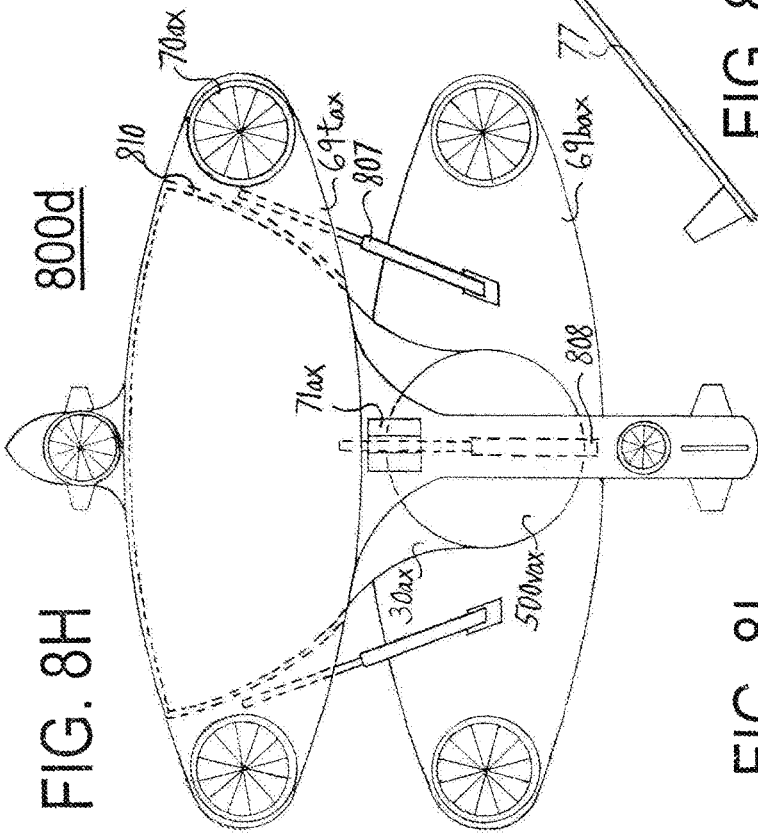


FIG. 8H

800d

FIG. 8J

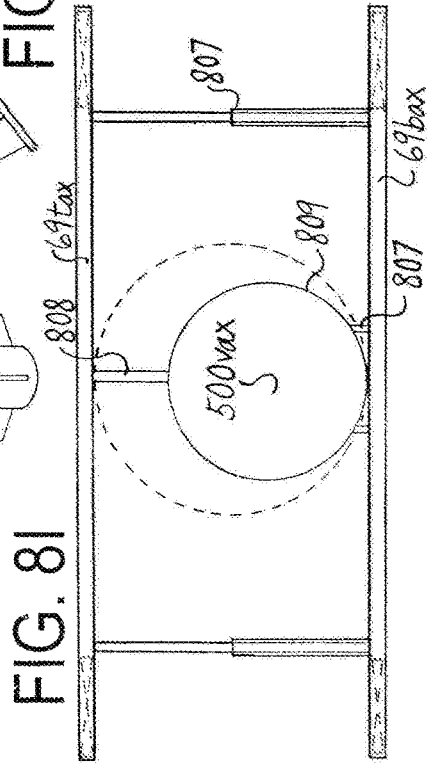


FIG. 8I

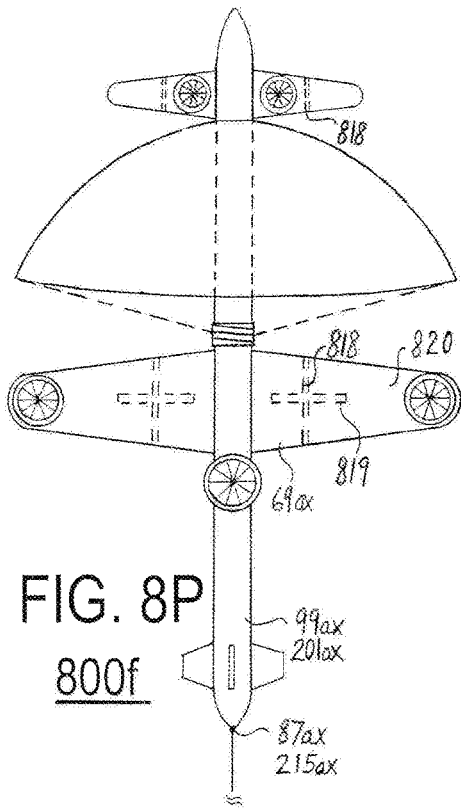


FIG. 8P  
800f

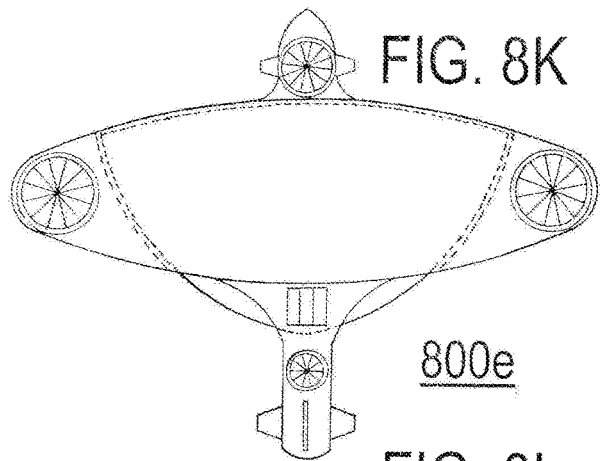


FIG. 8K

800e

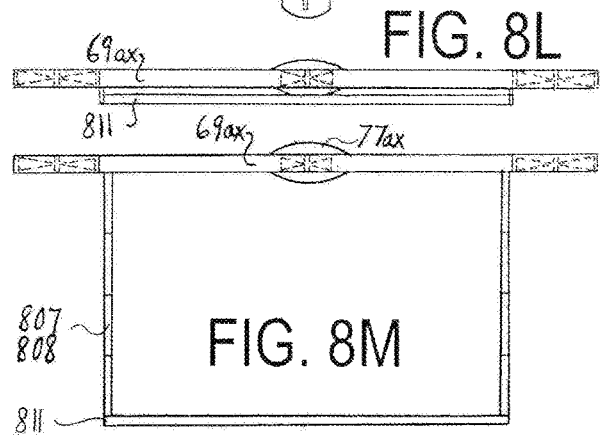


FIG. 8L

FIG. 8M

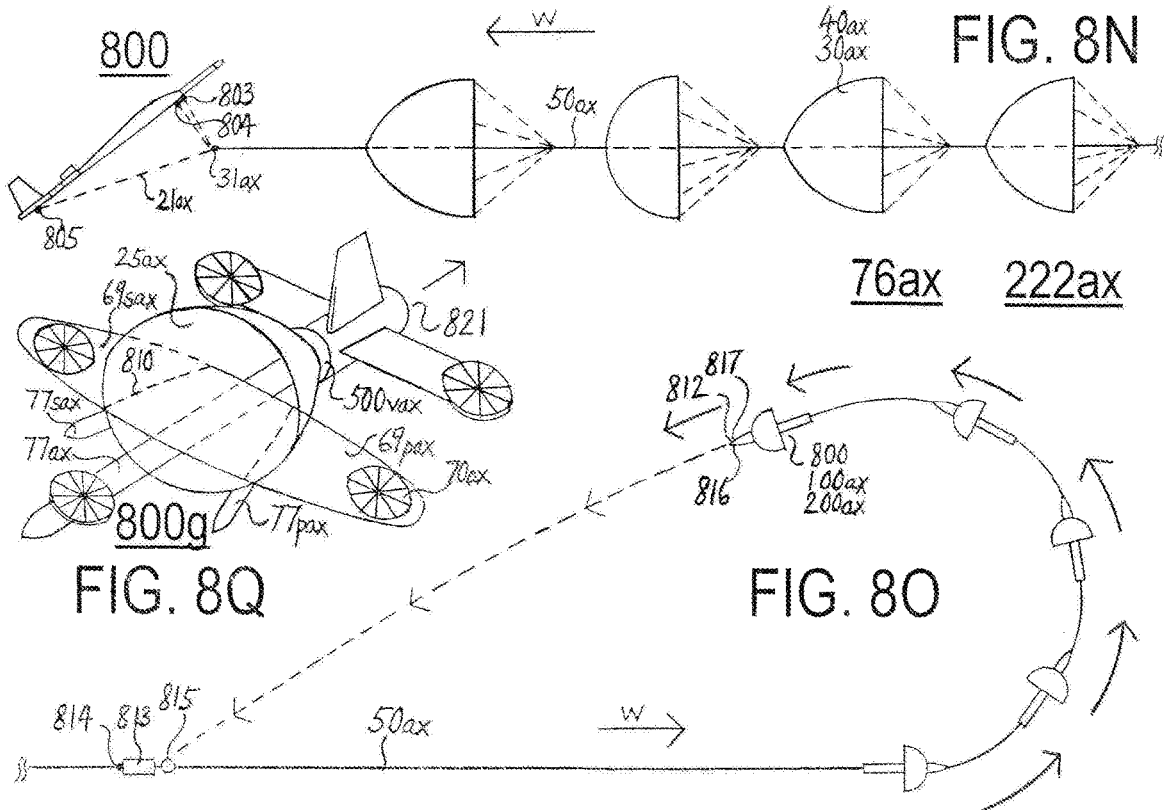


FIG. 8Q

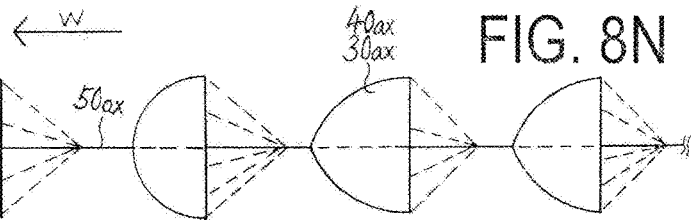


FIG. 8N

76ax 222ax

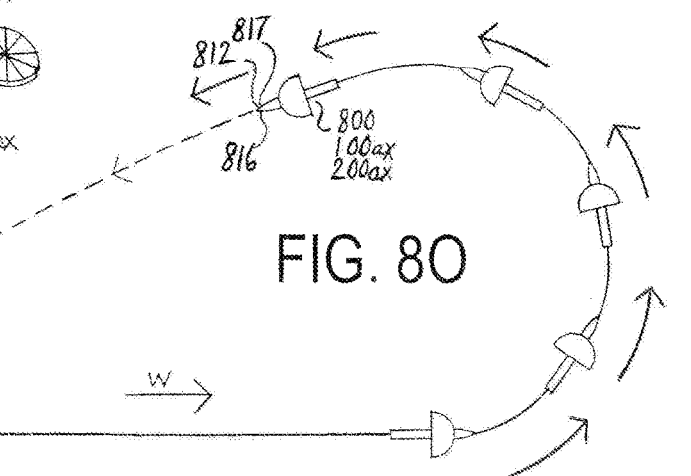
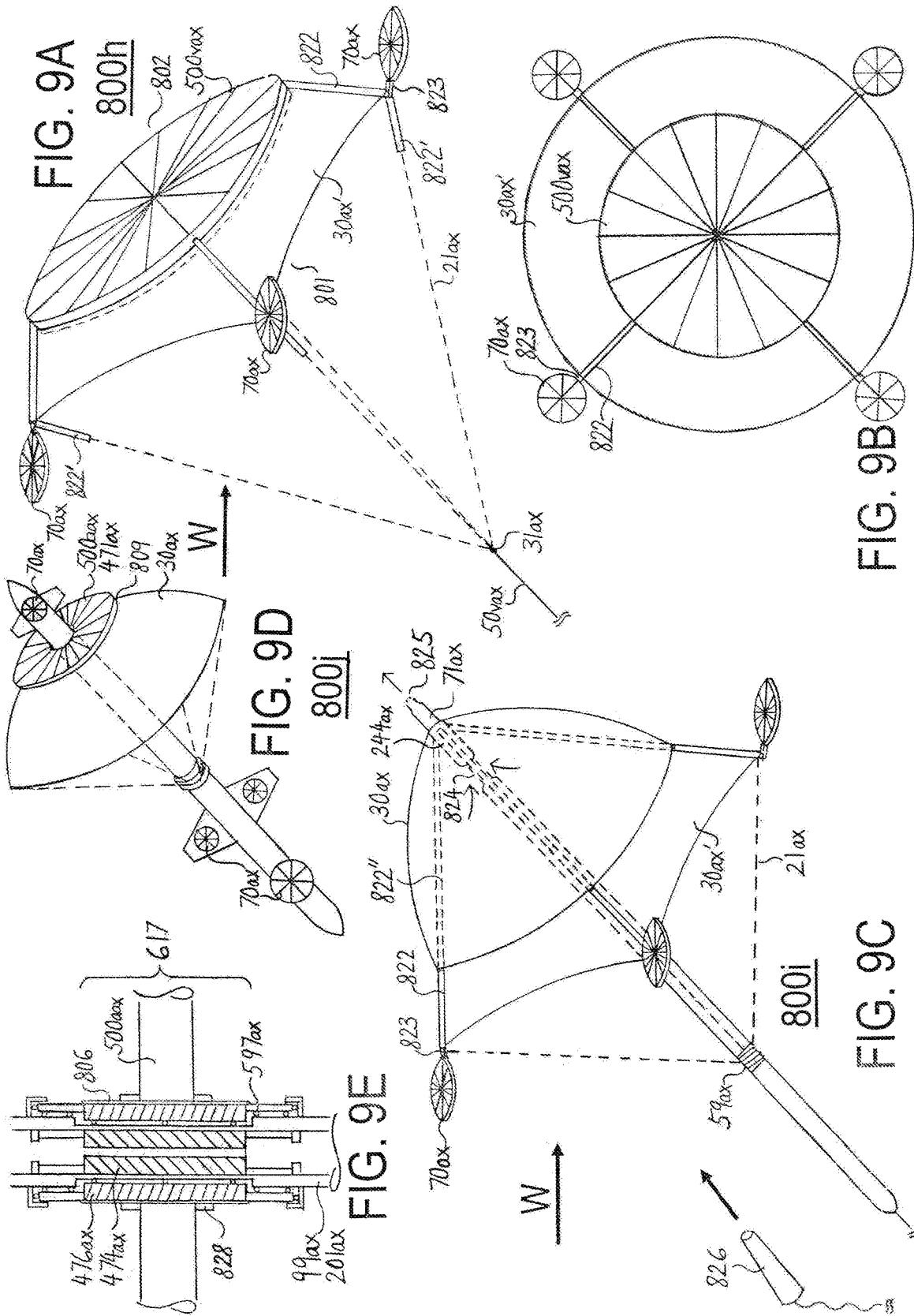
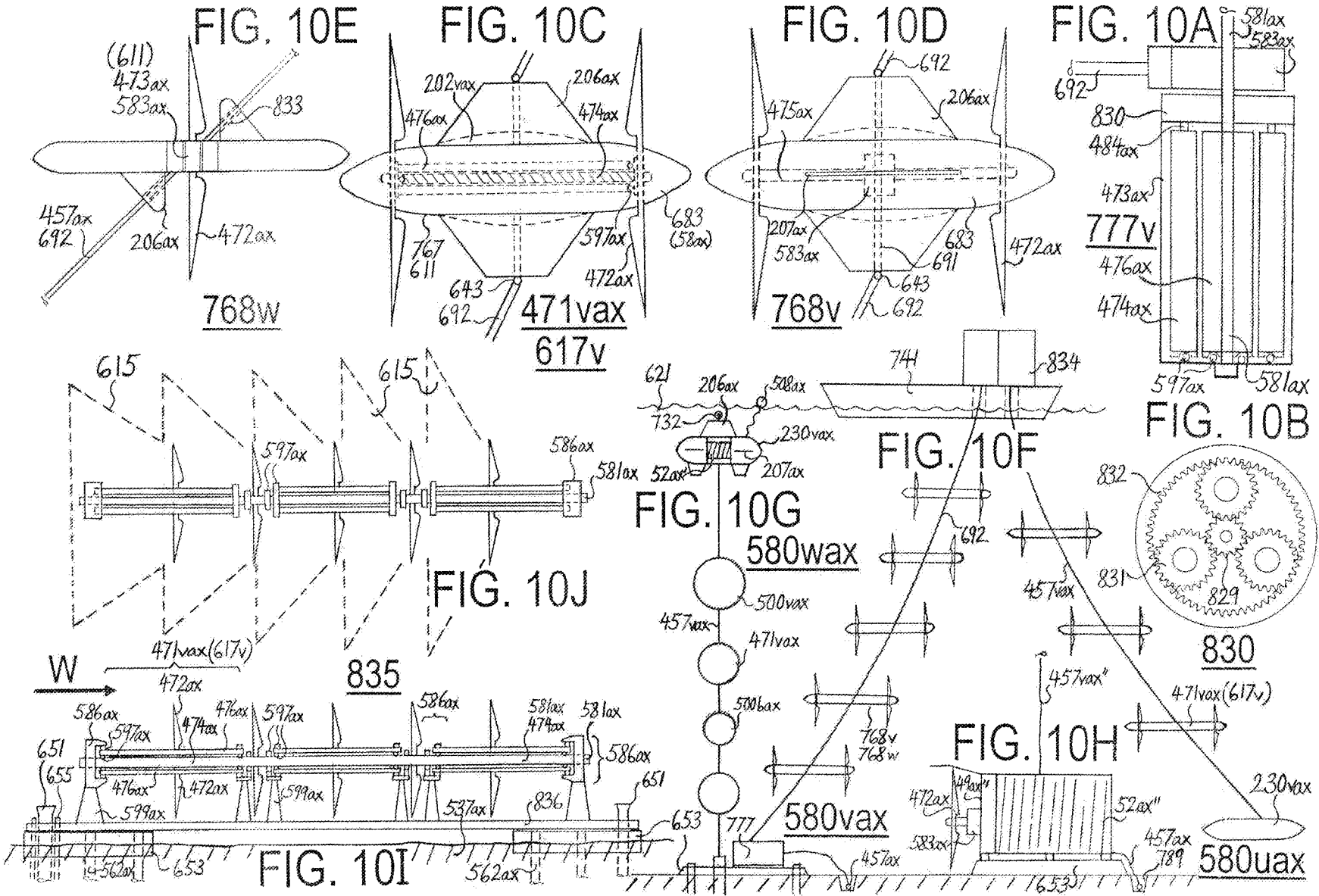
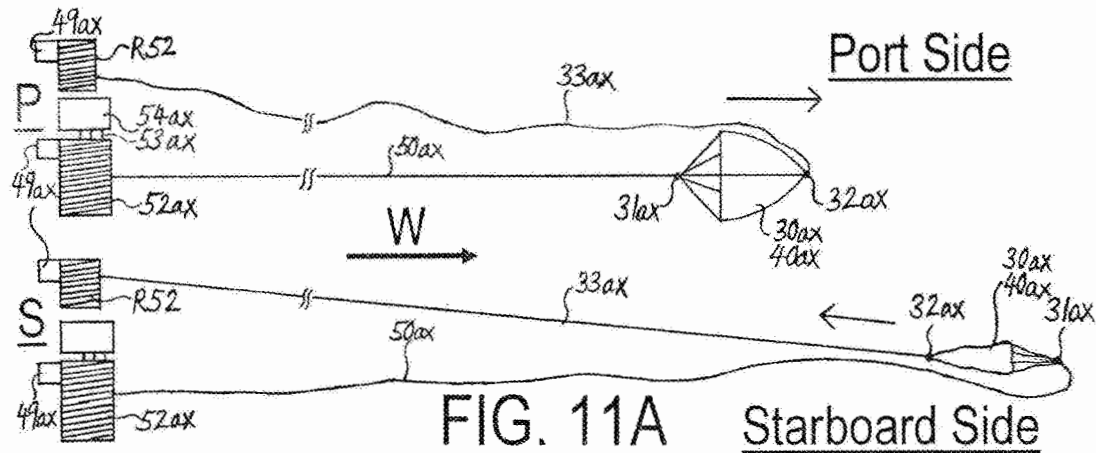
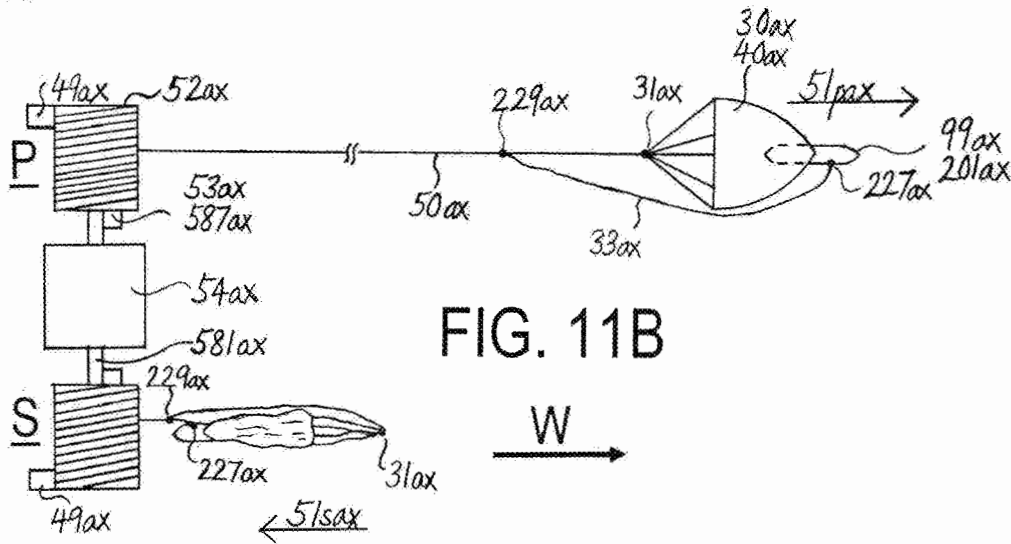
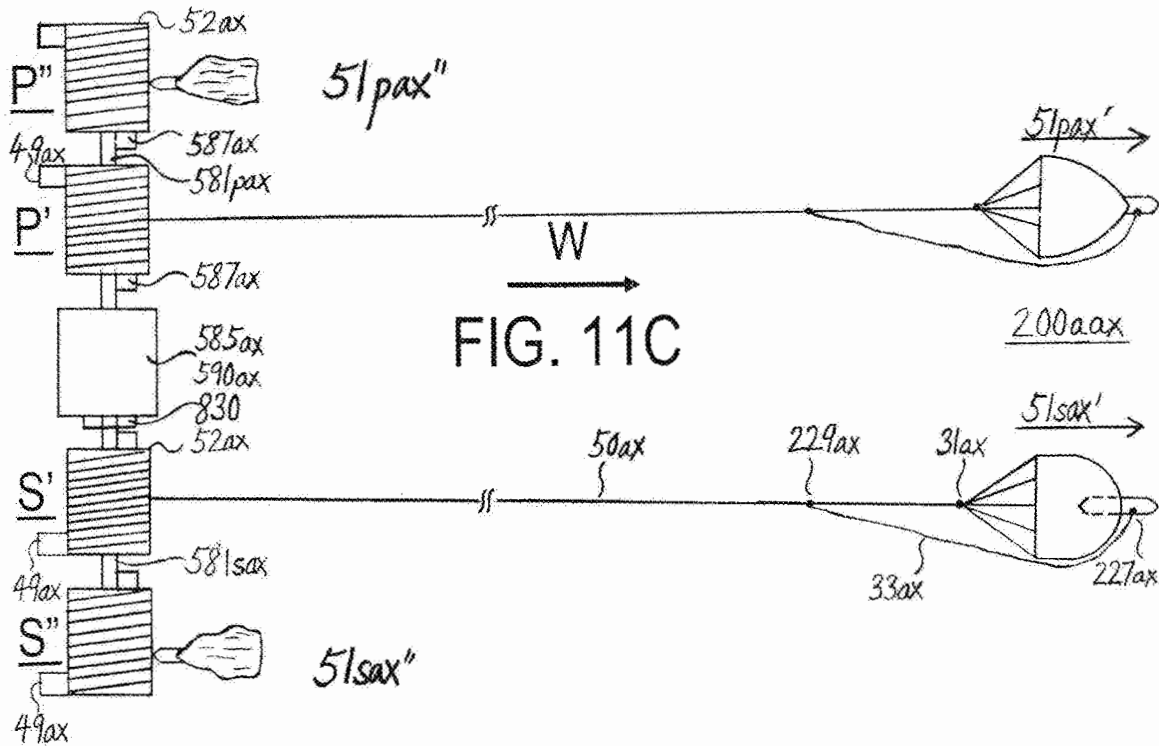


FIG. 8O







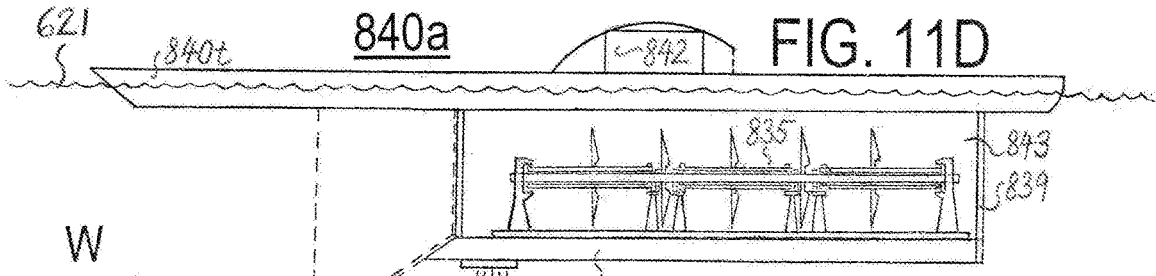


FIG. 11E

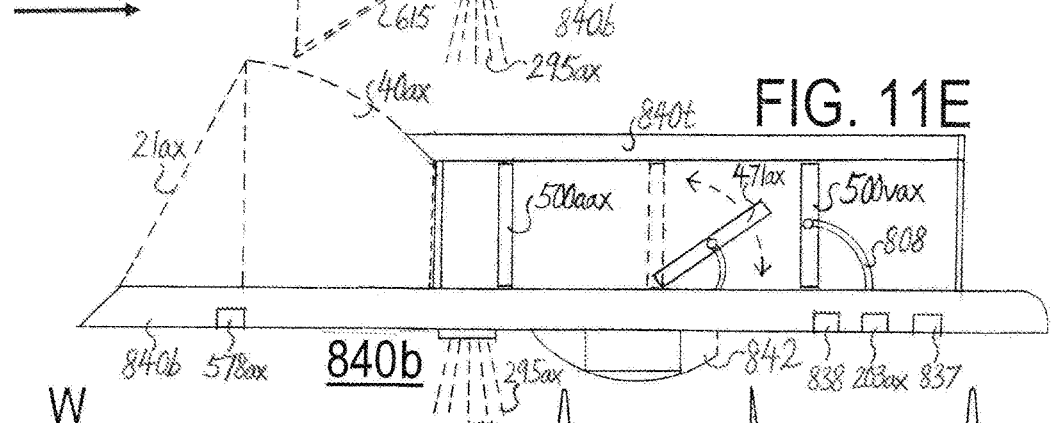
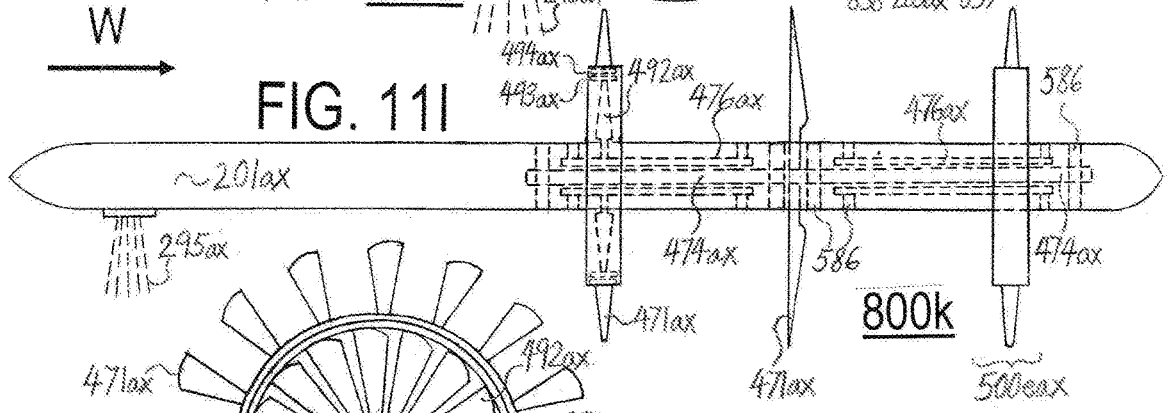


FIG. 11I



500eax

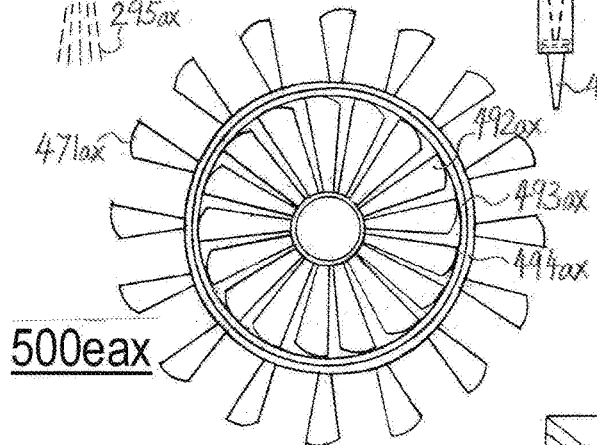


FIG. 11H

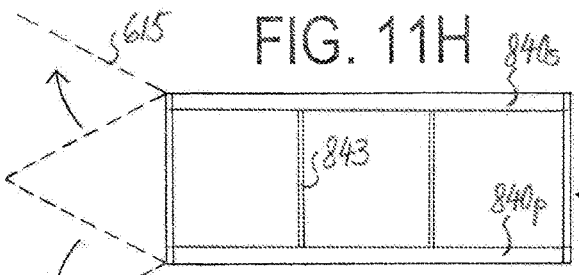
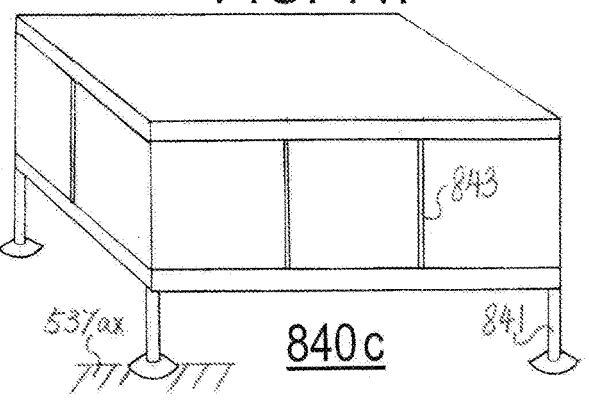


FIG. 11G

FIG. 11F



840c

## DRONE MOUNTED WIND TURBINE-GENERATOR SYSTEM

application claims priority to Singapore Application 10201807027W filed Aug. 20, 2018 and Singapore Application 10201907453Y filed Aug. 14, 2019, the contents of which are incorporated herein by reference for all purposes.

### FIELD OF THE INVENTIONS

Present invention provides some means in humanity's battles; war; our campaign for survival against Global Climate Change (GCC). Inventors may provide humanity with mitigating solutions such as: new tools; better equipment and systems. Enabling a transformation of our energy systems. From our present dirty fossil fuels based systems to non-polluting clean technologies. Mankind had 12 years to avoid the catastrophic effects of GCC (refer: UN-IPCC Report; Oct. 8, 2018). A million species faces extinction due to pressure created by humans (refer: UN Biodiversity Report, IPBES; May 6, 2019). However, whether we can overcome this "greatest challenge facing humanity." Whether our civilization can collectively survive beyond this critical test/or become extinct, too, maybe much more subjective. Much more dependent upon factors such as: political will-power; speed of deploying mitigating solutions; people's attitudes; conscious personal choices, decisions; climate leader-ship; climate activism, climate denialism; climate "murders", climate justice; etc. than mere physical devices.

Present invention discloses the utility purpose of deploying drones and adapting drone and robotic technologies for harnessing high altitude wind energy and deep sea ocean energy to generate renewable energy; displacing use of fossil fuels; mitigating the deadly effects of catastrophic global climate change. Ultimate Goal: safeguard and preserve our one and only life-support-system—Earth's Biosphere; in a habitable condition for all humans, animal and plant species to continue living! That the air we breathe, the water we drink remains clean and healthy; not poisoned by the toxic wastes we generate. Deploying robotic-drones to serve humanity. To generate clean energy; to preserve clean air and water; and a healthy planet Earth for future generations! That humans doesn't follow the dinosaurs—into extinction! Yeah, drones and robots! Drone-bots to the rescue of humanity! Drone-bots, new innovations, materials, systems and enabling means of the Fourth Industrial Revolution (4IR); controlled by means of computerized artificial intelligence (AI) may be used to save mankind from this self-inflicted ecological suicide! And in return generation of Ocean Renewable Energies to power the 4IR.

The harnessing of renewable "green" energy from the mass movement of naturally occurring fluid elements comprising wind and water (tide); the capture and transformation of this kinetic energy into useful mechanical energy by means of specialized apparatus and devices configured for producing electricity comprising: wind powered generators; tidal marine-hydro-kinetic powered generators. In particular wind energy comprising: high altitude wind energy; the Jet Stream. Marine-hydro-kinetic energy comprising: swift moving tidal currents and ocean gyres; the Gulf Stream. The engagement, capture, extraction, transformation and conversion of said fluid's kinetic energies into useful mechanical energy by means of specialized apparatus and devices. In one form, said fluids may be entrapped by means of shrouds, hoods, wingsuits **30ax** and routed from an enlarged intake port through a smaller constricted outlet port connected to an

energy conversion apparatus such as a turbine; a turbine-generator. Wherein, said fluid velocity may be amplified multi-fold; increasing system efficiency and productivity. Present and prior disclosures comprises: (a) Energy extraction systems: wherein kinetic energies present in fluids (wind; tidal-stream) may be systematically extracted and transformed into mechanical energies. (b) A reconfigured drive train may include a torque transmission system: wherein said mechanical energies may be conveyed from said energies extraction system in (a); to a generator. (c) Wherein said generator transformed the transmitted torque into useful electrical energies. Conversion of kinetic to mechanical to electrical energies.

Energy extraction systems of present invention may comprise single, integrated extraction-cum-direct-conversion units; for example: apparatus **617**; **471ax**; used the world over. This is the most efficient structural configuration. However due to location needs; components in nacelles requiring miniaturization (due to height and weight factors); and/or water-proofing (submerged at the bottom of the sea). Wherein, the drive-train of present invention may use similar systems such as apparatus **471ax**. Or, the drive train may optionally be reconfigured. Wherein, said split-unit system **600ax** may be configured for: extraction-conversion of the kinetic energies comprising wind and tidal energies into mechanical torque; transmission of said torque to surface based systems; its final conversion into electrical energy by means of counter-rotational-generation. A structural configuration **600ax** wherein renewable energies of wind and water currents may be extracted by means of a distributed and diverse energy extraction system (kinetic to mechanical energy); transmission of said mechanical energy by means of a torque transmission system **687**; into a centralized generation system consisting of: a split-unit segmented counter-rotational-generation system **777**; **585ax**; **590ax** (mechanical to electrical energy). Such a split-unit system **600ax** enables transmission of torque; from diverse sources comprising a multitude of energy extraction apparatus or devices (**100ax**; **200ax**; **400ax**; **500aax**; **600ax**; **700**; **740**; **800**;) into a specialty generator **777**; specifically configured to assimilate, accommodate, process and transform said diverse torque transmittal; by means of gearbox **583ax**; planetary gear **830**; shaft **692**; universal couplings **666**; into green electricity efficiently.

Such a system may be disadvantaged by inherent energy losses due to torque transmission (frictional losses). And may be slightly deficient (in efficiency) as compared to integrated extraction-cum-direct-conversion units **617**; **471ax**; **500aax**. However, such minimal losses may be easily made up for by increasing the capacity; or the number of energy extraction units. Structural advantages gained may include: centralized generation module **777**; larger energy extraction units e.g. bigger turbines mounted on the same structure (lighter); no need for expensive water-proofing; as the nacelles are now located on the surface (ground; deck-platform **736**); ease of access for periodic checks; maintenance and repair; enhanced occupational safety and health of crew, due to reduced exposure to hazardous work (minimized access to turbine nacelles located at the top of tall towers); lower operating costs. Ground or surface based generation systems may be configured to be: heavy-duty; huge and rugged; as compared to the much more delicate and light-weight generation components (turbine nacelles **473**) lofted into great heights by huge-tall cranes; located at the top of towers **469ax**. Or, smaller waterproofed nacelles located at the bottom of the sea and ocean.



In another structural improvement, moisture sensitive generating elements: **474ax**; **476ax**; may be encased; 5  
 unwrapped; embedded in; with a layer(s) of water repellent; water-proof materials comprising: plastics; composites; ceramics; glass; fiber-glass; carbon-fiber; Kevlar; Dynnema; etc. Optionally, the structural body frame-work of a generator may be used as an additional layer of separation. Effectively and physically segregating the more sensitive rotor coils **474ax** from the less sensitive rotor magnets **476ax**; though the mechanisms remains in close proximity to each other. The magnetic field penetrates through the thin layer(s) of water repellent materials into the coils beneath. The most important goal: isolating; segregating; separating said generating elements **474ax** and **476ax** from contact with: ambient moisture; high humidity; water.

The use of specialized drones; drone-robots integrated with robotic-mobility capabilities configured for the job of executing specific tasks required of them; for the effective functioning of the energy extraction farms/complexes. Doing work; jobs; tasks on apparatus and equipment located at great depths in the deep sea and oceans; and at high altitudes in the aerial environment. Use of Unmanned Aerial Vehicles (UAVs); Unmanned Underwater Vehicles (UUVs) and Remotely Operated Vehicles (ROVs); integrated with specialized robotic limbs **522ax**; tools; equipment; appliances; etc. Armed with autonomous capabilities supported by means of computerized cognitive Artificial Intelligence (AI) and decision making for the independent execution of assigned tasks by said integrated drone-robot units (drone-bots); configured to harness the kinetic energy of high altitude winds; and tidal energies of the deep sea and the ocean for doing useful work. A method, system, equipment, apparatus, techniques and a drone ecosystem configured with vertical scalability and a quantum leap in the generation of renewable green energy: electricity, in comparison with existing systems at a minimized environmental and aesthetic cost.

### BACKGROUND OF THE INVENTIONS

Present methods of harnessing wind energy by means of: kites, wind mills, wind turbines, kytoons, airfoils, etc.; use of sails on boat, ship or sledge for traction is known; as is the capture of water energy by means of: water mills, water wheels, turbines; balloons mounted on the sea-bed, floatation based devices, etc.; in converting the kinetic energy of wind into mechanical energy to do useful work: mills to grind flour, pump water, etc. including aero-electric power and hydro-electric power generation. However, some devices like: wind mills, wind turbines may be deficient and self-limiting due to (i) the minimized surface area for capture of the kinetic energy of the fluid medium as evidenced by the limited size and number of turbine blades, rotors, propellers, spokes; sails, etc. that may be affixed to an apparatus; (ii) the extremely short, momentary, contact time between the drive surface and the moving fluid medium providing the kinetic energy lasting a few seconds; and (iii) harnessing the kinetic energy in an ad-hoc randomized manner. Harnessing the energies of mother-nature in quantities huge enough for global consumption by means of utility scale generation plants/or farms; may require different approaches and solutions from conventional methods, systems and apparatus presently available. In particular high altitude wind energy, the Roaring 40's, the Furious 50's, the Shrieking/or Screaming 60's, the Jet Stream (exceeds 92 km/h; up to 398 km/h). The low altitude sector (800 m to 1 km) of wind energy typically harnessed by wind turbines

mounted on fixed towers comprises about 2% of the total global wind power. Whereas 98% of the global wind energy lies out of reach at a height of above 800 meters; and may be extracted by means of airborne wind energy systems operating above this altitude. Present invention discloses methods and systems for using a bagged energy collection system wherein tethered windbags and water-bags may be used in combination with ducted turbine-generators for producing green electricity.

### SUMMARY

Present invention discloses systems, methods and techniques of adapting and transforming the bodies of **99ax** and **201ax** of HAV-100 and HUV-200 into self-generating apparatus with the integration of turbine units powered by wind and water. The windbags **30** and water-bags **40** function as originally configured; enabling the engagement and conversion of energies in wind and tidal currents into useful electrical energy. The use of fixed solid state shrouds, hoods, ducts; casings affixed externally to turbines or used as a housing structure is known. Penstock **575**; or turbine housing **615** of present invention may also be used for: protection of turbines; and to keep wildlife out of the turbine blades. But most importantly, for improved efficiency by confining the high velocity fluid flow created by means of the equipment within the system; not spilt or lost to the surroundings.

Present invention discloses the use of windbags **30ax** and water-bags **40ax**; an apparatus/or device configured to work and act as: (1) a fluid collector for the capture and entrapment of moving fluid currents. (2) Configured to create the magnifier effects; for the multiplication and amplification of the inherent kinetic energy/or velocity in wind and water currents. Wherein said bagged apparatus work as a flow velocity magnifier; amplifier; enhancer; aggregator; congregator; a concentrator of kinetic energies. The amplification and transformation of this captured kinetic energy from a low speed to a much higher speed. Such that said bagged apparatus **30ax**; **40ax** may be used in tandem with the devices of present invention; or existing devices and appliances comprising turbines; or other energy conversion apparatus for the purpose of: (3) Enabling a multi-fold increase in efficiency and productivity in the generation of renewable energies.

### BRIEF DESCRIPTION OF THE DRAWINGS

Preferred embodiments of the present invention will now be described with reference to the accompanying drawings wherein:—

FIG. 1A shows a perspective side view of an integrated wind energy capture and direct conversion apparatus **610a**. FIG. 1B shows a parallel apparatus of FIG. 1A. An integrated tidal energy capture and direct conversion apparatus **610b**.

FIG. 1C shows a wind energy amplification apparatus **670**; used with a hooded direct conversion turbine generator. FIG. 1D shows a side view of a wind energy amplification apparatus; used with vertical axis turbine generators. FIG. 1E shows a perspective view of FIG. 1D. FIG. 1F shows an enlarged view of FIG. 1D. FIG. 1G shows a split unit tidal energy extraction; transmission; and generation system **620**.

FIG. 2A shows a circular shaped inlet port **25ax**. FIG. 2B shows an oval shaped inlet port. FIG. 2C shows an oblong shaped inlet port. FIG. 2D shows an inverted oblong shaped inlet port of FIG. 2C. FIG. 2E shows a rectangular shaped inlet port. FIG. 2F shows a square shaped inlet port. FIG. 2G

shows a semi-circular shaped inlet port. FIG. 2H shows a trapezoid shaped multi-sided inlet port. FIG. 2I shows a bag with an enlarged inlet port.

FIG. 2J shows a floating windbag system **630a**. FIG. 2K shows a dual purpose floating—submersible water-bag system **620b** cum windbag system **630b** with integrated turbine-generators **611**. FIG. 2L shows a large underwater rectangular shaped water-bag **40ax** with integrated turbine-generators **611**; mounted on vertically inclined beams and pillars. FIG. 2M shows an air bellows-clamping apparatus **633**.

FIG. 3A shows the perspective view of an underwater system **620d**. FIG. 3B shows a side view. FIG. 3C shows a plan view. FIG. 3D shows a variant apparatus **644**; while FIG. 3E shows a variant apparatus **619**; both used in operating and controlling the inlet port **25ax** size.

FIG. 3F shows a the use of detachable drilling pipes **650** with permanent drill pipes **660** in securing system **620d** into position. FIG. 3G shows a permanent subsea foundation **660** for anchoring apparatus **620d**.

FIG. 3H shows the side view of a windbag system **670** with a split unit configuration. FIG. 3I shows a plan view. FIG. 3J shows the rear view of **670** with the plurality of ducted fluid outlet ports **614**.

FIG. 3K shows an integrated underwater turbine-generator system **690** combined with a ballast tank **578ax**. FIG. 3L shows an automated ballast control system **686**. FIG. 3M shows a sectional view of helical shaped screw turbine **613**.

FIG. 4A shows a submerged split unit marine turbine-generator system **700** and supporting ecosystem. FIG. 4B shows a sectional view **4B-4B** of system **700**; FIG. 4C shows a variant configuration of FIG. 4B. FIG. 4D shows a side view of renewable energy farm **710**; while FIG. 4E shows a plan view.

FIG. 4F shows a side sectional view; while FIG. 4G shows a perspective view of apparatus **711**. FIG. 4H shows cross-section **4H-4H** of **711**. FIG. 4I shows a front view of apparatus **712**. FIG. 4J and FIG. 4K shows customized apparatus **730**; for servicing and repair of turbine-generator **700**.

FIG. 5A shows a split unit ocean energy conversion system **740**; comprising a multitude of differing drive units used for extraction of ocean renewable energies of wind and tidal power; transmission of mechanical energy harvested; to the centralized driven unit. FIG. 5B shows a variant configuration of system **740**.

FIG. 5C shows the combined use made of a variety of tidal and wind energies extraction apparatus for powering counter-rotating generators **585ax**; **590ax**. FIG. 5D shows mechanical torque transmission by means of: belt and pulley wheels apparatus; and a roller chain and sprocket apparatus.

FIG. 5E shows the plan view; while FIG. 5F shows the frontal view of a variant configuration of tidal turbines and horizontal axis wind turbines mounted on turn-tables on floating platform **740v**. FIG. 5G shows an integrated tidal turbine-generator **611**. FIG. 5H shows the side view; FIG. 5I shows the frontal view of a surface based floating system **750**. A variant combined wind turbine cum tidal turbines generation system.

FIG. 5J shows the frontal view; while FIG. 5K shows the side view of a tidal energy farm. A flotilla of underwater turbine-generators **700** suspended in the ocean at various depths may be supported by means of anchoring lines affixed to the seabed; and to a surface floating platform. FIG. 5L shows turbine-generator **700** attached to; and held in position by lines **295ax**.

FIG. 6A shows an ocean energy farm **770** comprising a multitude of turbines attached to extended shafts running between two structural bodies **771**; **607**. The extended shafts driving two generators at either end. Or, both ends. FIG. 6B shows a turbine enclosed by floats. FIG. 6C shows details of ring **774**. FIG. 6D shows details of cross-section **6D-6D**. FIG. 6E shows details of flexibly connected turbine blades **472ax**.

FIG. 6F shows a variant configuration of counter-rotating generator **777**.

FIG. 6G shows a perspective view of an enclosed marine structure **771**. FIG. 6H shows a plan view of system **770**; comprising structures **771** affixed to seabed **537ax**. Multiple interconnected marine structures **771** may be arranged to maximize harvesting of ocean renewable energies comprising: solar; wind; tidal; wave energies. FIG. 6I and FIG. 6J shows a flexibly extendable and retractable extended shaft **692**.

FIG. 6K shows a variant structure **780a** configured with a plurality of horizontal axis wind and tidal turbine **472ax** mounted on a monopile **788**; for use in shallow water. FIG. 6L shows a variant structure **780b** for use in deeper-waters. FIG. 6M shows a plurality of vertical axis tidal turbines **477ax** and wind turbines **477ax**. Mechanical torque derived from said multitude of turbines **472ax**; **477ax** may be transmitted by shafts **692**; combined together to drive a single centralized generator **777**; on surface deck **736**.

FIG. 7A shows a combined solar-wind-tidal-wave energies generation platform **290ax**. The collected torque may be used to power a surface based generator **777**. FIG. 7B and FIG. 7C shows the side; and plan view of a marine; hydro; riverine renewable energies farm **790a** configured with fluid diversion walls **790**. Tidal flow channeled by means of tidal dykes/or sea fences **790** may increase tidal velocity; for driving vertically; or horizontally aligned generators **777**. FIG. 7D shows a perspective view; FIG. 7E shows a plan view of a structure comprising a plurality of vertical and horizontal beams erected for extraction of ocean energies. Structural beams maybe integrated with ducted penstock **575ax**; tidal turbines **472ax**. Torque generated may collectively be transmitted to power generator **777**.

FIG. 7F shows a floating Spars structure **607ax** integrated with wind and tidal turbines **472ax**; their output (torque) combined for powering generator **777**. FIG. 7G shows a perspective view; FIG. 7H shows a sectional view of a sea dyke **790**; creating a tidal lagoon **798**. Turbines in tunnels **799** converts tidal energies to mechanical; to electrical energies (**777**).

FIG. 8A shows a plan view; FIG. 8B shows a perspective side view of: an aerial drone **800a** integrated with a wind powered turbine-generator **500aax**. FIG. 8C shows a drone **800b** of FIG. 8A and FIG. 8B integrated with a variant ultra-light-weight turbine-generator **500vax**. FIG. 8D shows a variant self-propelled aerial drone **400vax** integrated with a plurality of additional motorized turbo-fans **70ax**.

FIG. 8E to FIG. 8G shows a morphing drone **800c** of FIG. 8A with dual sets of wings **69ax**; (**404ax**). One larger set of wings **69bax** at the bottom; with one smaller set of wings **69tax** stacked above in an over-under configuration. Wind bag **30ax** may be mounted between twin wings for traction-generation of electricity alike HAV-100ax. Or integrated with a high velocity turbine **500aax**; **500bax**; **500cax**; **500dax**; **471ax**.

FIG. 8H to FIG. 8J shows a variant morphing drone **800d** of FIG. 8E to FIG. 8G with dual sets of similar sized wings **69ax**. In flight the bottom set of wings **69bax** may be flipped backward; towards the rear. At cruising height, wings **69bax**

may be flipped forward and downward (over-under) forming a bi-plane's normal configuration. FIG. 8J shows the side view of drone with twin set of wings configured to form a tapered, funnel, "V"-shaped aerial apparatus (fore to aft) with turbine generator **500vax** inside.

FIG. 8K to FIG. 8M shows a drone **800e** configured with a rectangular shaped inlet port **25ax** for traction-generation of electricity. FIG. 8N shows a variant plain drone **800** leading a series of windbags or water-bags **76ax**; **222ax** for traction-generation of renewable electricity. FIG. 8'O' shows a master drone vehicle leading a series of drones during the depowering phase before the retraction phase (return back to base).

FIG. 8P shows a variant drone vehicle **800f**; wherein vehicle **100ax**; **200ax** may be modified with improved propulsion and lift generation means for better efficiency. FIG. 8Q shows a variant drone **800g** (a hybrid airplane-rocket shaped body) configured with a shrouded turbine-generator **500vax** located aft.

FIG. 9A to FIG. 9B shows a variant drone apparatus **800h** wherein, a self-propelled turbine-generator unit **500vax** may be configured with a shrouded wingsuit **30ax** at its periphery; multiple turbine propulsion units **70ax** mounted on struts **822**. FIG. 9C shows a variant drone apparatus **800i** of FIG. 9A and FIG. 9B wherein, a self-propelled traction-generation unit HAV-100a may be similarly configured. Turbine-generator **500vax** may be replaced with a windbag **30ax**; water-bag **40ax** for traction (drive unit **51ax**) of a surface mounted driven unit (generation) **55ax**.

FIG. 9D shows a variant drone apparatus **800j** of FIG. 9A to FIG. 9C wherein, said turbine-generator **500vax**; windbag **30ax**; water-bag **40ax**; may be mounted on a rocket-shaped body **99ax**; (torpedo-shaped body **201ax**;) configured with airplane wings **69ax**; hydroplanes **205ax**; and propulsion units **70ax**.

FIG. 9E shows a specially configured turbine-generator **500aax**; **500bax**; of FIG. 9D wherein, said electrical and magnetic elements may be waterproofed and externally sealed in a robust layer of water resistant composite materials. Such protective coatings may be used with electrical generation components of underwater drones; or aerial drones which may be exposed to high moisture content.

FIG. 10A to FIG. 10B shows a counter rotating generator **777v** configured with a planetary gears apparatus **830**; for conversion of torque; from one input into two output. FIG. 10C to FIG. 10E shows a plurality of underwater tidal turbines configured for direct generation of electricity; generation of torque and its transmission. FIG. 10F to FIG. 10H shows differing arrangements for deploying said plurality of floating tidal turbines. FIG. 10I shows a bottoms based tidal turbines system **835** affixed to seabed. FIG. 10J shows an arrangement of shrouds **615v** for concentrating tidal flow into system **835**.

FIG. 11A to FIG. 11C shows differing configuration of the drive units **51ax** and driven units **55ax** of present invention. From fully manual systems to fully automated systems using drones. From rotor—stator to counter-rotating rotor—rotor configuration. FIG. 11D to FIG. 11G shows the integration of turbine generators **500aax**; **835**; with pontoon bodies **840**. Enabling said turbines to be deployed from the top to the bottom of the water column. FIG. 11H and FIG. 11I shows the use of turbine-generator **500eax** with HUV-200vax.

#### DETAILED DESCRIPTION OF THE INVENTIONS

The structural configuration, concept, method and system of providing bagged drone bodies integrated with turbines

for harnessing and extracting the energies contained in a moving air (wind) and water current for the generation of electricity; is herein disclosed. Transforming its kinetic energy into mechanical and then electrical energy by means of a turbine. In this specification, all reference numbers made to previous disclosures (in parent patent applications) are denoted with the alphabets "ax".

FIG. 1A illustrates system **610a**; the adaptation and transformation of the body **99ax** of a HAV-100/and or the structural body **201ax** of a HUV-200 into a self-generating apparatus **610a** with an integrated turbine-generator **611a** (nacelle) located to the fore of body **99ax**; **201ax**. Wind bag **30ax** or water-bag **40ax** may be used to capture the moving fluid medium. Modifications may include the use of a plurality of air pillars **420ax** to reinforce support of airbag **30aa** or water-bag in addition to the existing inflated inlet port ring **22ax**; air-ribs **277ax**; a plurality of fluid diversion ports **612** incorporated into the body structure **99ax** or **201ax** to channel wind and/or water flow captured by inlet port **25ax** to a turbine-generator apparatus **611a**. The integrated turbine-generator apparatus **611a** may comprise of a helical-screw type impeller-turbine **613**. After passing through apparatus **611a** the fluid leaves by means of exit port **614**. Turbine generator **611a** may be configured surrounded by a ducted housing **615**; a variant of confined penstock **575ax**. The whole apparatus may be protected and surrounded by: a balloon **58ax** filled with lighter than air gas such as hydrogen or helium; or, a buoy **508ax**; or, a ballast container **578ax**. The container **578ax** and turbine-generator **611a**; or the whole apparatus **610a** may also be attached by means of lines **295ax** to a supporting body such as a kytoon; aerostat **45ax**; blimp **45ax**; power kite; glider; glider-drone **400M**; HAV-400ax; UAV **80ax**; powered glider-kite-drone; etc. The apparatus **610a** may also be secured by means of lines or tether **46ax**; **50ax**; **295ax**; to fixed anchoring pillars **625**; beams **626**; beams **708**; jacket legs **291ax**; fixed platforms **290ax**; etc.

FIG. 1B illustrates system **610b** a variant of system **610a** (FIG. 1A); wherein said airbag **30aa** or water-bag **40aa** may be supported by a plurality of struts **232ax'**; **232ax"** attached to a hub **224ax** activated by means of a pneumatic; or, hydraulic system **244ax** concealed inside the body **99ax**; **201ax**. (Refer FIG. 9A and FIG. 9B of U.S. Pat. No. 8,963,362). The variant segmented plurality of struts **232ax'**; **232ax"** may be elongated and/or contracted by means of hydraulic or pneumatic pressure from concealed system **244ax** inside body **99ax**; **201ax**. The plurality of turbine generators **611b** incorporated at the fore portion of the apparatus may be configured such that the internal bore (passage) of the turbine blades **616** may be made progressively larger as the fluid moves from fore to aft; from sections S1 to S2 to S3. Such that turbine generators of section S1 may experience the highest velocity; while Section S2 may experience reduced velocity. Section S3 may experience the lowest velocity. Such a structural configuration may help to avoid build-up of back-pressure upstream of the turbine blades **616**; at fluid diversion ports **612**. Because back pressure at the exit port **614** meant that fluid captured by the collection windbag **30aa** or water-bag **40aa** is being spilt. Over-flowing from the brim; from the sides of the inlet port **25ax**; from inside of the fluid filled cavity **19ax** out into the open and thus, lost. Such a deficiency reduces the efficiency of the apparatus **610a**; **610b**. The crux lies in utilizing all of the fluid collected with zero spillage. That is, conversion of all of the fluid's kinetic energy into mechanical energy; which is then transformed into electrical energy.

FIG. 1C illustrates two separate units comprising: (1) system 670; a wind or water energy collection; capture and conversion system enabled by means of a windbag 30aa or water-bag 40aa wherein; said wind or water current entering the inlet port 25ax may be channeled by means of diversion ports 612; through exit nozzle 614 (without a turbine-generator 611 in between); and directed onto an, (2) integrated stand-alone ducted 615 turbine-generator 617 (with nacelle). For the purpose of illustration, the two apparatus (1) and (2) may be split; and located some distance away from each other. Apparatus 670 may comprise of a windbag supported by a pillar 618'; 618"; a body 99ax/or 201ax; struts 232ax'; 232ax"; inlet port 25ax; exit port or nozzle 614. By itself, said turbine-generator 617 is able to capture the inherent velocity of the ambient wind (for example: wind velocity at 2 m/s; turbine swept area 2 m<sup>2</sup>) to generate electricity. Using the formula:  $Power = \frac{1}{2} \rho Av^3 C_p$ . Apparatus 617 generates a power of: 6.183 Watts. However, if the individual units (1) and (2) are combined together their productivity may experience an exponential increase. Wherein power generated may undergo a multiplier effect when turbine-generator 617 is used in combination with the kinetic energy concentrating and velocity enhancing bagged apparatus 670. For example: due to the large difference in size between the inlet port 25ax (20 m) versus the outlet port/or exit port nozzle 614 (2 m); at a wind velocity of 2 m/s. The ratio between inlet area versus outlet area is: (20 m x 20 m) versus (2 m x 2 m) = 10:1. According to Bernoulli's equation: the velocity at the exit nozzle 614 is 100 times more (faster) than the velocity at the inlet port 25ax. Applying the formula;  $Power = \frac{1}{2} \rho Av^3 C_p$ ; the power imparted by this stream of high velocity fluid onto the turbine-generator 617 being: 6.183 MW. A comparison may be made between: turbine generator 617 configured without apparatus 670 (6.183 Watts). Versus turbine-generator 617 configured with velocity enhancing apparatus 670 (6.183 MW). Indicates an exponential (theoretical) increase of 1,000,000 times—a quantum leap in power generation; created by means of a simple bagged apparatus 670! But due to the separation and open distance between apparatus 670 and turbine-generator 617; etc. much lesser conversion efficiency may be expected due to spillage of high velocity fluid. The above figure of 1 million times is only a theoretical illustration. This is impossible to achieve practically. There are physical limits as to how much fluids may be compressed.

To take full advantage of the above; optimized harvesting of the concentrated kinetic energies generated by apparatus 670 may be achieved by means of integrating apparatus 670 with apparatus 617. Wherein unit (1) and (2) may be combined together. To maximize productivity and conversion efficiency the external duct 615; or housing 615 of apparatus 617 may be directly connected with the exit nozzle 614 of apparatus 670. Thus the outlet port/or exit nozzle 614 of apparatus 670 may be integrated with the ducted 615 turbine-generator 617 in a closed; enclosed or confined system. Wherein by means of a ducted; shrouded; or confined system configuration; the full force, the full impact of the high velocity fluid created by the bagged apparatus 670 may be brought to bear directly on the blades of ducted turbine-generator 617. Such that the high velocity fluid created is fully utilized. Not spilt, dispersed or lost to the surrounding unnecessarily. Wherein a bagged apparatus 30ax; or 40ax; may be configured for use with multiple units of turbine-generators 617; 611a; 611b; 471ax; 472ax; 477ax; etc.

The advantages of using such a kinetic-energy magnifying bagged apparatus 670 in tandem with turbine-generator 617 (or any other turbine-generator) is obvious. Because even by scaling up the ducted 615 blades of turbine-generator 617 (by 10 times) from 1 m to 10 m length (20 m diameter swept area); 2 m/s wind velocity. The quantity of power generated by a standalone apparatus 617 is only 618.3 watts. A hundred times more than the original 1 m turbine length (2 m diameter swept area) of 6.183 watts. But still 10,000 time less than the power generated; as compared to when apparatus 617 is used in tandem/or integrated with apparatus 670 (6.183 MW).

Therefore, turbines may be made smaller. But made much more robust; sturdier; tougher and stronger to withstand super high velocities created by means of apparatus 670. The windbags 30ax; water-bags 40ax may be made larger and taller to maximize collection; gathering and energy extraction of wind and tidal currents. The bagged 30ax; 40ax power generation system 670 may be configured to work with supporting apparatus and equipment of variant systems 610; 620; 630; 477ax; etc. to enhance the efficiency and productivity of any other (fluids) wind and water energy conversion apparatus; devices; systems; equipment; etc. such as: horizontal axis turbines; vertical axis turbines; etc. As illustrated in FIG. 1D to FIG. 1F below.

FIG. 1D to FIG. 1F illustrates variant configuration of FIG. 1C; wherein, system 619 comprising two crane booms 619p; 619s; positioned port and starboard holding a windbag 30ax; may be configured to work in tandem with vertical axis turbines 477ax. System 619 comprises: a windbag 30aa mounted on and supported by twin crane booms 619p; 619s; on the port and starboard sides; with an exit port 614. Wind current entering inlet port 25ax may be channeled by means of diversion ports 612 mounted on body 99ax; through exit nozzle 614 (without a turbine-generator 611 in between); and directed onto a pair of vertical axis turbine-generators 477pax (port); 477sax (starboard); which may be located a short distance away from the exit nozzle 614. Exit port 614 may be configured in a rectangular shape for working with twin vertical turbines 477pax and 477sax. Said turbines 477pax; 477sax; rotating in opposite directions to each other as illustrated in FIG. 1E. While FIG. 1F illustrates a variant oblong shaped exit port 614 configured to work with multiple units of self-generating vertical axis turbines 477vax (with nacelles); supported by a pillar 618. For maximum efficiency; apparatus 619 may be combined with apparatus 477vax. Wherein, exit port 614 and apparatus 477vax may be configured; connected with an oblong shaped duct 615; to effectively channel the concentrated flow of high speed fluid for producing electricity.

FIG. 1G illustrates a variant split unit energy conversion system 620a; wherein a water-bag 40ax may be used with variant system 620a derived from: system 575ax; and system 600ax. (Refer FIG. 6R; FIG. 7A to FIG. 7H; of pending application U.S. Ser. No. 15/630,670.) Wherein said arrangement comprises of an underwater: (1) turbine 472ax (kinetic energy to mechanical energy conversion); (2) extended flexible torque transmission shafts 595ax; angular transmission gearbox 583ax; a couple of joints of universal coupling 666 (mechanical energy transmission apparatus); may be interfaced with, (3) a variant surface based electrical generator 577vax (mechanical energy to electrical energy conversion); mounted on floating buoy 508ax; ballast vessel 578ax; which may in turn be moored to the seabed 537ax by means of cables 295ax. Apparatus used for torque transmission (mechanical energy) may also comprise of: chains and sprockets (used in bicycle and motorcycle); and pulley

wheels and belts (used in vehicle alternators; air-conditioning; industrial machines). Switch gears **622**; transformers **622**; rectifiers **622**; sub-stations **622** may be securely and appropriately mounted in sheltered locations abroad floating surface buoys **508ax**; ballast vessels **598ax**; or surface support vessels **632**.

FIG. 2A to FIG. 2H illustrates the various configuration and different shapes of the inlet port **25ax** that may be used to enable optimized capture of wind and water currents by means of windbag **30ax** and water-bags **40ax**. FIG. 2A illustrates a circular shaped inlet port **25ax**. FIG. 2B illustrates an oval shaped inlet port. FIG. 2C illustrates an oblong shaped inlet port. FIG. 2D illustrates an inverted oblong shaped inlet port of FIG. 2C turned upside down. FIG. 2E illustrates a rectangular shaped inlet port. FIG. 2F illustrates a square shaped inlet port. FIG. 2G illustrates a semi-circular shaped inlet port. FIG. 2H illustrates a trapezoid shaped multi-sided inlet port. FIG. 2I illustrates a bag with an enlarged inlet port. A plurality of inflated inlet port rings **22ax**; air ribs **277ax**; horizontal air pillars **420ax**; vertical air pillars **420ax**; securing lines **66ax**; **623**; reinforcement straps **624**; solid body frame work **99ax**; **201ax**; concrete pillars **625**; concrete beams **626**; anchoring lines **627**; etc. may also be used to reinforce and maintain the desired shape of the inlet port **25ax** and bags **30ax**; **40ax** for their intended utility purposes. Inlet port ring **22ax** may also be spilt into individual sections; comprising a plurality of pieces (e.g. 4 pieces for square or rectangular shaped inlet port **25ax**) which may be inflated and used to maintain the shape of inlet port **25ax**; keeping it open. Line **23ax** configured behind inlet port ring **22ax** may be used to control the size (opening) of the inlet port. Line **23ax** may also be used to keep the inlet port **25ax** shut after maintenance, prior to deployment or mobilization. Or to shut the inlet port **25ax**; keeping it in a closed position during demobilization.

FIG. 2J illustrates system **630a**; a floating, semi-circular shaped wind-bag **30ax** and turbine-generator module **611** mounted on a plurality of buoys **508ax**; ballast vessels **578ax**; supported by structural body member **99ax** and air pillars **420ax**; inlet port ring **22ax**; air-ribs **277ax** embedded with bridle line **21ax**; straps **624**. Apparatus **630a** may be secured by means of anchoring lines **295ax** to undersea piles **562ax** affixed to the seabed **537ax**. Anchoring lines **295ax** may also be secured to other anchoring apparatus adapted and modified into geologic features as disclosed in FIG. 6R of the pending parent application U.S. Ser. No. 15/630,670. FIG. 6R discloses: "such geologic features may comprise seamounts **555ax** and islands **560ax**. Submerged seamounts **555ax** may comprise: guyots **556ax**; pinnacles **557ax**; knolls **558ax**; etc. Such that surface unevenness in the topography comprising: holes; indentations; protrusions; fissures; cracks; nooks and crannies, etc. of the seamounts **555ax**; submarine ridges **559ax**; trenches **561ax**; canyons; seafloor **537ax**, etc. may be adapted, modified and converted for use as anchoring points for securing lines **295ax**. By means of man-made apparatus comprising: piles **562ax** and pillars **545ax**; reinforced concrete beams **563ax**; cement plugs **564ax**; holes **566ax** drilled and artificial grooves **567ax** cut into suitable places of the rocky features of the seamounts **555ax** and islands **560ax**. Such that anchor lines **295ax** may be secured to pillars **545ax** and piles **562ax**; lines looped around small hills, pinnacles **557ax**; ridges **559ax**; lines looped through holes **566ax** held securely in recessed grooves **567ax**; etc."

FIG. 2K illustrates a combined wind and water energies conversion apparatus comprising: an aerial system **620b**; and an underwater system **630b**. A dual purpose semi-

submersible windbag **30ax** and water-bag **40ax** with a circular inlet port **25ax**. If and when coincidentally, the wind blows and the seawater flows in the same direction, such an apparatus may be used to harness the energies of both the wind and tidal currents at the same time. Wind and marine hydro-kinetic currents entering the inlet port **22ax** of the bag exits through twin wind and water turbine-generators **611** mounted (over and under) at the aft of the body **99ax** (**201ax**); The apparatus may be supported by air pillars **420ax**; buoys **508ax**; ballast tanks **578ax**; and anchoring lines **295ax** secured to piles **562ax**; pillars **545ax**; in the seabed **537ax**. When the wind changes direction the apparatus may be converted into a water-bag and became fully submerged; by relocating the buoys **508ax**; ballast vessel **578ax** to the top of the water-bag **40ax**; and adjusting their ballast. The reverse may be done to fully convert the apparatus into a windbag.

FIG. 2L and FIG. 2M illustrates system **620c**; a water-bag **40ax** configured with a rectangular shaped inlet port secured by a multitude of lines **627** to a plurality of vertically inclined concrete pillars **625** and concrete beams **626**; affixed and/or inserted to the seabed **537ax**; mooring buoys **508ax** and ballast tanks **578ax**. The lines **627** used to secure bag **40ax** to pillars **625**; and bellow-clamp **633**; may be held by an outer plastic cover **628** which is flexible and pliable. The top and bottom portions of outer cover **628** may be linked to two pulley wheels **629t**; **629b** by means of dual strands **631'**; **631''**; of a closed loop line **631**. Pulley **629t** and the top portion of line **631** may be borne by a buoy **508ax**; or supporting vessel **632**. While pulley **629b** bearing bottom portion of line **631** may be affixed to the seabed **537ax**. Such an arrangement enables ease of deployment and powering up of the water-bag **40ax**; and its depowering and recovery for maintenance and repair purposes.

Such an apparatus may be configured with the inlet port measuring 1 km square to 10 km square in size. And may be equipped with multiple units of turbine-generator **611**. Electrical energy generated by integrated turbine generation units **611** may be transmitted by underwater transmission lines **457ax** secured to ballast tank **578ax**. Units **611** may also be mounted on mechanical arms configured with hydraulic jacks **619**. Optionally, the split unit energy conversion system **620a** of FIG. 1G may be used. Wherein the drive units comprising turbines **472ax** for kinetic to mechanical energy conversion remains submerged under the sea. While the driven units comprising heavy and extremely delicate electrical generation elements and/or related electrical components **622** remains on the sea surface; mounted and sheltered inside ballast vessel **578ax** or support vessel **632** in a dry and secure environment; protected from the wind and corrosive sea water. Said drive unit and driven unit components connected in between by a mechanical energy transmission system comprising extended shaft **595ax**; angular transmission gearbox **583ax**; a couple of joints of universal coupling **666**; etc.

FIG. 2M illustrates sub-system **633**; comprising an air bellow-clamping apparatus used to flexibly secure the plurality of lines **627** onto concrete pillars and beams **625p**; **625s**; **626**. Apparatus **633** may be mounted on and borne by net **628**/or cover **628**; which may be slipped over vertical pillars **625p**; **625s**. Apparatus **633** includes: a strong rigid outer ring **634**; a plurality of flexibly configured air bellows **635**; attached with a plurality (of pieces) of clamps **636**. Lines **627** connected to the periphery of water-bag **40ax** may be attached and positioned on the inner-most ring of clamps **636**; lying in between the clamps **636** and pillars **625p**; **625s**. A plurality of apparatus **633** may be moved into their desired

positions on pillars **625p** and beams **625s** by means of netting cover **628** and dual pulley lines **631'**, **631"**. The apparatus **633** may be inflated by means of air pump **637**; compressed air being supplied by means of air line **638**. Low pressure air from line **638** going to air pump **637** may be used to supply and to operate pump **637** to increase its discharge air pressure going to the bellows **635** of apparatus **633**. High pressure air inflating the flexible bellows **635** causes it to expand; pushing it hard against the rigid outer ring **634**; and the pillar **625p**; or beam **625s** located at the center. Causing the clamps **636** holding lines **627** to clamp tightly on to the pillar **625p**; beam **625s**; sandwiching the lines **627** tightly in between, holding them in position. When compressed air or water is released from the bellow **635**, the securing lines **627** are let loose. Water-bag **40aa** may be retrieved together with apparatus **633** by means of netting cover **628** attached to dual lines **631'**, **631"**; powered by motorized **639** winch **629t**.

For ease of system operability the protruding top portions of vertical pillars **625p**; **625s**; and beams **626p**; **626s**; may be configured in an inclined position; slanted backwards; towards the aft position; towards the downstream side of the tidal stream flow. Such that retrieval of said bagged generation system **630c** during demobilization may be assisted by the natural flow of fluid current. The tidal flow pushing the components downstream; pushing the bottom portion of the inlet port **25ax** upwards; narrowing the size of its opening; and depowering the system naturally when inlet port **25ax** became shut. This structural inclination working in tandem with the motorized **639** reeling of lines **631'**, **631"**; by means of pulley wheels **629t** and **629b** in bringing the water-bag upwards; towards the surface of the sea **621**. During mobilization, the inlet port **25ax** may be kept shut, fully closed, and the whole bag lowered to the bottom of the sea in a closed position. The bellow-clamps **633** located at the bottom, the lowest level may be deployed first; followed by the bellow clamps **633** located higher up, in the middle. And finally the bellow-clamps **633** located at the top. With the bag gradually opening up from the bottom; to the middle; then to the top.

FIG. 3A to FIG. 3F illustrates a variant configuration **620d** of the system **620c** illustrated in FIG. 2L and FIG. 2M. FIG. 3A illustrates the perspective front view of a water-bag **40ax** mounted on a solid rectangular framework. FIG. 3B illustrates the sectional side view of FIG. 3A. FIG. 3C illustrates the sectional plan view of FIG. 3A and FIG. 3B. The rectangular inlet port **25ax** comprises of: a top horizontal beam **640t**; a bottom horizontal beam **640b**; two sets of vertically aligned movable arms **641** and **642** attached by hinged joints **643** located at the port and starboard sides. The two sets of vertically aligned arms; one set each mounted at the port side **641p**; **642p**; **643p**; and the starboard side **641s**; **642s**; **643s**; allows movement of the top and bottom horizontal beams **640t**; **640b**; akin to a fish's mouth opening and closing. The entire apparatus **620d** may be attached to an anchoring apparatus **650** by means of **4** supporting struts **648p**; **649p**; **648s**; **649s**; two each (located port; starboard sides) connected to the top beam **640t** and bottom beam **640b**. FIG. 3D illustrates a variant configuration wherein said vertically aligned arms **641**; **642**; **643**; optionally may comprise of a scissors like design; wherein a multitude of short struts **644** connected together by means of hinged joints forming a scissors-like mechanism may be opened and closed; elongated and collapsed; thus opening and closing the inlet port **25ax**. The top and bottom horizontal beams **640t**; **640b** may be attached to the body **99ax**; **201ax** of the apparatus by means of struts or mechanical arms **645t**; **645b**.

Twin mechanical jacks **619t**; **619b**; may be used to manipulate the struts or arms **645t**; **645b**; which in turn moved the top and bottom horizontal beams **640t**; **640b**; causing the inlet port **25ax** to open or close as required. Enabling variable control of the size of inlet port **25ax**. FIG. 3E illustrates a variant configuration wherein struts or arms **645t**; **645b**; may be configured to comprise of two mechanical jacks **619t**; **619b**; working like twin crane-booms controlling the top and bottom beams **640t**; **640b**; and thus the size of inlet port **25ax**. The entire apparatus **620d** may be attached to an anchoring apparatus **650** by means of **4** supporting struts **648p**; **649p**; **648s**; **649s**; two each (located port; starboard sides) connected to the top beam **640t** and bottom beam **640b**. Swivel anchoring apparatus **650** may in turn be affixed to the seabed or seafloor **537ax** by means of a plurality of piles **562ax**; and/or pillars **545ax**. Two struts each on the port side **648p**; **649p**; and the starboard side **648s**; **649s**. FIG. 3F illustrates the flexibly configured drilling strings apparatus **650** which may be used to enable mobilization and demobilization of the entire apparatus **620d**.

FIG. 3B illustrates the sectional side view of FIG. 3A. Tidal current flows through the inlet port **25ax** formed by horizontally disposed top and bottom boards **640t**; **640b**; and twin vertically disposed side arms or struts **641**; **642**; connected by hinged joint **643** located at the port side (not shown) **641p**; **642p**; **643p**; and starboard side (shown) **641s**; **642s**; **643s**. Tidal current passes by inclined twin arms **645t**; **645b**; operated by means of hydraulic or pneumatic jacks **619t**; **619b**; entering via a plurality of diversion ports **612**; before going through body **201ax**; then into turbine-generators **611**; then finally exiting through outlet port **614**. FIG. 3C illustrates the sectional plan view of FIG. 3A and FIG. 3B; showing a plurality of diversion ports **612** on the enlarged structural body **201ax**; connected to a plurality of turbine-generators **611**. Detachably configured turbine-generators **611** may be attached to or disconnected from the structural body **201ax** for maintenance and servicing purposes.

The ocean energy harvesting apparatus **620d** may be used to collect, entrap and capture tidal currents using an enlarged inlet port **25ax**; channeling and concentrating the fluid; amplifying its velocity; forcing it through a plurality of integrated turbine-generators **611** (with nacelle); then released through the outlet port **614**. Water current flows through large apertures **612** on the mounting body **201ax** before entering three turbine-generators **611**. Body **201ax** may be configured to function as an automated ballasting and de-ballasting vessel for balancing and buoyancy control of the whole ocean tidal energy conversion apparatus **620d**; configured with integrated turbine-generators **611**. Such that the self-supported apparatus is weightless; or exhibits minimal weight in the water. Body **201ax** may also be utilized for carrying other equipment and apparatus; such as the plurality of pneumatic or hydraulic system **244ax** operated mechanical jacks **619t**; **619b**; for opening and closing the inlet port **25ax**. Said jacking mechanisms **244ax** mounted on the body **201ax** operated said struts or arms **645t**; **645b** connected to the top and bottom horizontal beams **640t**; **640b**; opening or closing the inlet port **25ax**. The weight of the turbine-generators **611** may also be supported by means of lines **295ax** attached to mooring buoys **508ax** and submersible ballast vessels **578ax**. Power generated may be transmitted by means of underwater cables **475ax**. Turbine-generators **611** may also be configured with fully automated, integrated ballast and buoyancy control tanks (refer FIG. 3I and FIG. 3J). The surface buoys **508ax** and submersible

ballast vessels **578ax** located fore and aft above apparatus **630d** may be connected together by means of a floating network of solid structural beams **652**; grid **703**; including struts; truss; lines; etc. for constituting a floating platform for production and processing of ocean renewable energies comprising: solar; offshore wind; and marine hydro-kinetic energies including tidal stream energies.

Referring to FIG. 3A and FIG. 3F; the anchoring system for apparatus **620d** may comprise of: a removable component **650**; and a fixed component **660**. Enabling apparatus **620d** to be flexibly yet securely anchored to a foundation comprising of: a plurality of drill pipe **651** (drill string **651**) and piles **562ax** affixed into the seabed **537ax** by means of reinforced concrete slabs **653**. Or by means of concreted natural caverns or artificial caverns **565ax** drilled into the bed rocks **537ax**. The fixed component **660** of the anchoring apparatus may comprise of a drill pipe **651** spudded into the bed rock of the seabed **537ax** (cemented in position alike drilling and completion of wells in the oil and gas industry) affixed together with a plurality of sub-sea piles **562ax** by means of reinforced concrete **653**. The detachable component **650** of the anchoring apparatus may comprise of: a flexibly configured collar-sleeve **654**; a modified short drill pipe **655**; and normal lengths of drill pipes **656**. Upon which apparatus **620d** may be attached via collar-sleeve **654**. And supporting facilities comprising of a drilling machine with mechanical arms **657** bearing a rotating turn-table **658**; abroad drill ship **659** with drilling rig **659'**. Collar-sleeve **654** bearing the 4 anchoring struts **648p**; **649p**; **648s**; **649s**; may be affixed onto and integrated with the modified short drill pipe **655** in the middle. Collar-sleeve **654** and drill pipe **655** may be configured to rotate independently of each other. For utility purposes the threads of the male coupling **656m** and female coupling **655f** of drill pipes **656** and **655** may be modified; and configured to work in a direction opposite to that of the male coupling **655m** and female coupling **651f** of drill pipes **655** and **651**.

During mobilization of apparatus **620d**, the whole apparatus may be deployed in a collapsed form with the inlet port **25ax** kept fully shut. The entire apparatus **620d** may be borne by means of collar-sleeve **654**; and the drill pipe **655**. The male coupling **656m** of a detachable drill pipe **656** may be mated with (screwed tight by means of threads and grooves) the female coupling **655f** of drill pipe **655**. Drill pipe **656** may be borne by a rotational drilling apparatus **658**; held in place by mechanized arm **657**; with all equipment carried by a modified drilling ship **659**/or drilling rig **659'**. Mated drill pipes **655**; **656** bearing apparatus **630d** may be lowered from the surface of the sea towards anchoring drill pipe **651**; assisted by means of homing signals transmitted by sonar transceiver **299sax**; detected by sonar receiver **298sax**. Sonar receiver **298ax** may be attached to collar-sleeve **654** or drill pipe **655**. Sonar transceiver **299ax** may be attached to the concrete slab **653** or drill pipe **651**. In proximity male coupling **655m** of drill pipe **655** may be slotted into the top funnel shaped female coupling **651f** of drill pipe **651** (fixed anchoring apparatus). Additional lengths of drill pipes **656'**; **656''**; etc. may be affixed to existing drill pipe **656** if required. The drill pipes **656**; **655** may then be rotated by means of rotating apparatus **658** (e.g. clock-wise) abroad drill-ship **659**. Male and female threads on the drill couplings **654m** and **651f** mated in place and tightened as a result. However, further turning of the drill pipes (pre-configured; desired outcome) causes the male and female couplings **656m** and **654f** between drill pipes **656** and **655** to loosen; detaching from each other. Resulting in drill pipe **656** separating from drill pipe **655**. Drill pipe **656** may

be removed; retrieved from apparatus **620d** back to the surface and drill ship **659**/drilling-rig **659'**. Drill pipe **655** bearing apparatus **620d** remains securely attached to anchoring drill pipe **651** at the bottom of the sea. Other components comprising ballast tanks **578ax**; mooring buoys **508ax**; turbine generators **611**; electrical transmission cables **457ax**, etc. may be brought into position; connected; checked out; tested and deployed. The inlet port **25ax** may be operated to open up last; by means of central struts **645t**; **645b**; and mechanized jacks **646t**; **646b**. Water current flows into the apparatus **620d** and out through exit ports **614**; generating renewable electricity; which may be channeled by means of submarine cables **457ax** to the sea surface **621** based rectifier **622**; transformers **622**; switching gears **622** mounted on mooring buoys **508ax** and ballast tanks **578ax**; and for transmission to shore facilities.

During demobilization, a reversal of the mobilization process may be executed. Wherein the inlet port **25ax** may be operated to close shut first; by means of central struts **645t**; **645b**; and mechanized jacks **646t**; **646b**. Then the drill pipe **656** mounted on turntable apparatus **658** carried by mechanical arms **657** may be lowered from the drill ship **659** towards drill pipe **655** bearing collar-sleeve **654** and apparatus **620d**. In close proximity, the male coupling **656m** of drill pipe **656** is mated with the female coupling **655f** of drill pipe **655**. The drill pipe **656** turned by turntable **658** (e.g. anti-clockwise) causes the coupling joints of pipes **656** and **655** to tighten. Further turning of drill pipes **656** and **655**; causes the male coupling **655m** of drill pipe **655** to loosen, unscrew and then detach from the coupling joint between coupling **655m** and **651f**. This causes apparatus **620d** to be separated from the anchoring apparatus **651** which is affixed to the seabed **537ax**. Buoyancy of submarine bodies **201ax** may be maximized and air may be blown into water-bag **40ax** by means of air lines **204ax** to increase buoyancy. The entire apparatus **620d** including turbine-generators **611** may then be raised up to the surface. Flexibly configured turbine-generators **611** may be detached from the submersible body **201ax**. Equipment checks; maintenance and repair works may then be carried out.

FIG. 3F illustrates the use of detachable component **650** together with the fixed component **660**; enabling easy mobilization and demobilization (installation and removal) of the entire apparatus **620d**. Once constructed the fixed component **660** of the anchoring apparatus remains a permanent feature. Only the detachable component **650** of anchoring apparatus comprising: collar-sleeve **654**; normal length of drill pipe **656**; modified short drill pipe **655** upon which apparatus **620d** is attached; may be installed onto; and/or removed from the fixed component **660** as desired. By means of supporting facilities such as ship **659** borne drilling rig **659'** configured with drilling machines with mechanical arms **657**; and rotating turn-table **658**. Prior to installation of apparatus **620d**; modified short drill pipe **655** bearing collar-sleeve **654** and apparatus **620d** may be affixed to a normal length of drill pipe **656**. And then lowered into the sea. If required, additional lengths of drill pipes **656'**; **656''**; **656'''**; etc. may be affixed to the existing drill pipe **656**; one after the other; to extend total pipe length until it reaches the fixed anchoring drill pipe **651**. Drill pipes **655** and **656** may be rotated by means of turntable **658** borne by mechanical arms and hydraulic jacks **657**. The direction of rotation may be used to tighten or loosen specific joints as desired; and as per design configuration. In particular the make-up of coupling joints **651f** and **655m**; and then the detachment of coupling joints **655f** and **656m**; during installation of apparatus **620d**. And during demobilization or removal of apparatus **620d**;



the make-up of coupling joints **655f** and **656m**; and the detachment of coupling joints **655m** and **651f**.

FIG. 3G illustrates details of a subsea foundation **660** used to securely affix the anchoring drill pipe **651** in position. By means of a technique used in the oil and gas industry; modified for provision of a subsea anchoring apparatus **660** for the production of ocean renewable energies; not for production of oil and gas. A foundation hole **566ax** may be drilled into the bedrocks of seabed **537ax** in a preferred location by means of standard drill bits. The bottom portion of the hole **566ax** may be purposely made larger than the top portion. A modified drill pipe **651** configured with a multitude of spring-loaded hinged appendages **661** may be inserted into the drilled hole **566ax**. The self-folding and self-extending spring loaded appendages **661** may be configured to bend aft (towards the rear; backwards) when drill pipe **651** is inserted into hole **566ax**. At the bottom portion of the hole **566ax** which is larger than the top portion; the spring-loaded appendages **661** extended outwards horizontally. Those appendages **661** located at the narrower top portion of hole **566ax** extended outward against the wall of hole **566ax**; pointing backwards towards the top of hole **566ax**. Such that once it is inserted drill pipe **651** remains stuck inside the hole **566ax**. It cannot be retrieved. The drill pipe **651** and hole **566ax** may then be cemented in place by means of concrete slurry **663** pumped through an internal bore hole **662** in the middle of drill pipe **651**. Concrete slurry **663** exited bore hole **662** by means of bottom perforation **662b**; filling up the entire cavity **566ax**; displacing sea water. Excess concrete spilling out of hole **566ax** formed a concrete mound **663** at the neck of pipe **651** on seabed **537ax**. The structure is left to harden and cure. Thus forming an artificial man-made subsea concrete **663** plug **564ax** inside hole **566ax** with embedded pipe **651** securely anchored into the bed rocks **537ax** of the seabed. Such modified techniques may also be adapted and used to create embedded artificial plugs **564ax** inside any naturally occurring cavities in the seabed **537ax** or seamounts **555ax**. Similarly a plurality of piles **562ax** and pillars **545ax** fitted with appendages **661** may also be inserted into drilled holes **566ax** and cemented into position. Piles **562ax** may also be driven into the seabed **537ax** by conventional means.

FIG. 3H to FIG. 3J illustrates a variant split unit energy conversion system **670**; a variant version of system **575ax** and system **600ax** (Refer FIG. 7D; FIG. 7G; of pending parent application Ser. No. 15/630,670. FIG. 3H shows the side view of the aft portion of a split unit energy conversion system **670**; a large airbag **30ax** configured with twin rows of variant ducted turbines **472ax** (with turbines only; no generating elements) in an over-under (upper-lower) arrangement. FIG. 3I illustrates the plan view of FIG. 3H showing windbag **30ax** with a multitude of ducted **615** turbines **472ax** mounted aft. While FIG. 3J illustrates the rear view of said arrangement of ducted **615** turbines **472ax**. The plurality of ducted **615** turbines **472ax** may be attached to the structural body **99ax** by means of twin C-clamps **665**. The split unit generation system **670** (similar to FIG. 1G) may constitute four main sections: (a) wind-velocity concentration section; (b) energy extraction section; (c) torque transmission section; and (d) electrical energy generation section. Wherein, said respective sections may comprise of: (a) windbag **30ax** with large inlet port **25ax** and constricted funnel **671** located aft; (b) ducted **615** turbines **472ax** section (drive unit); (c) transmission gearbox **583ax** and extended torque transmission shafts **595ax** section; and (d) surface based generation **590ax** section (driven unit). Kinetic energy of the wind current is converted into mechanical energy by

the turbines **472ax**. The mechanical energy generated by the turbines **472ax** may be transmitted by means of transmission gear boxes **583ax**; and long extended shafts **595ax**; **692** to generators **590ax** on the surface/or ground. Extended shafts **595ax** may also be connected with a couple of joints of universal couplings **666** at each end enabling flexible and pliable transmission of angular torque. Rotating shaft **595ax** may be protected by an external cover **592ax**. For support extended shafts **595ax** covered by casing **592ax** may be configured next to; or near to the mechanical hydraulic jacks **619** on which ducted **615** turbines **472ax** may be mounted. The self-propelled generator **590ax** may be motorized **668** with wheels **669** for mobility.

The aft section of windbag **30aa** may be configured with a plurality of wildlife escape hatches **680**. Sub-system **680** may comprise of: reinforcement funnel **671**; a safety net **573ax** or cage **573ax** to screen, divert and channel wildlife; through a plurality of wildlife escape hatches **680**. Reinforcement funnel **671** helps prevent caving in or collapse of bag fabrics due to the pressure difference created by the venturi effect. At the aft section in particular; high velocity flow of fluid (low pressure) inside the windbag; contrasts with low velocity flow (high pressure) ambient atmosphere outside the bag. This may cause bag fabrics to cave inwards. Safety net **573ax**; or cage **573ax** may be mounted on and supported by a plurality of struts **672** and truss **672** attached to funnel **671**; and central body **99ax**; **201ax** structure. Wildlife escape hatches **680** may be mounted on the sides of funnel **671** which provides a solid frame for the apparatus to operate. The angular V-shaped configuration of the safety cage **573ax** ensures any wildlife e.g. a bird; a fish; entering the bag is swept to the sides of the bagged system by the wind or tidal current. Where a motion sensing-detection system **673** upon sensing the presence of said bird; fish; triggered activation of mechanism **674** controlling the operation of sliding trap door **675**. Thus exposing the escape hatch **680** allowing said bird; or fish to exit. Such a system cum apparatus **680** avoids injuring or killing wildlife; and at the same time, avoids unnecessary down time due to damaged turbine blades **472ax** caused by "biologics-strike" comprising: bird strikes and/or fish strikes. Damages may also be caused by debris; plastics; etc.

Such a split unit energy conversion system **670**; or split unit generation system **670** (drive unit; torque transmission unit; driven unit) may entail some loss of energy during the total energy conversion process. This system is in contrast with an integrated turbine-generator unit with nacelles **611**; **611a**; **611b**. Wherein, extraction of the kinetic energies of offshore wind and tidal currents and their direct conversion; from kinetic energy into mechanical energy; and then into electrical energy; may be carried out in one step by a single apparatus; instantaneously; as illustrated by apparatus **611**; **617** (refer FIG. 1A to FIG. 1C). This is the most efficient system configuration and is widely used worldwide at present. But very expensive. However in the split unit energy conversion system of present invention; this minor loss of energy and efficiency; may be more than offset by the advantages gained. As surface based systems are inherently much more: easier to design; cheaper to manufacture; components and equipment configured may be heavy duty, bulkier and more durable; easier to access, maintain and repair. With relocation of the heavy, yet extremely delicate electrical generation components (driven units) to the surface; the lighter (kinetic to mechanical energy) conversion components (drive units) comprising: turbines **472ax**; flexibly extended shafts **595ax**; **692**; transmission gear boxes **583ax**; universal couplings **666**; that are left: (a) high up in



the air (supported by apparatus **618**; **619**); and (b) deep down in the sea and ocean; entails a much lighter load to support. Thus with a simple modification the same infrastructure may be used to enable the deployment of turbines with larger blades; and energy conversion devices with much larger surface areas, volumes, etc. Thus compensating for the small energy loss incurred; restoring productivity; efficiency of the split unit energy conversion system; at par with direct energy conversion system using integrated turbine-generation units **611**; **617**. But with the renewable energy conversion plant built at a cheaper cost; more heavy-duty and durable; easier to maintain and repair. However direct energy conversion systems had its advantages; units **611**; **617** may be used to complement the system whenever desired.

FIG. 3K to FIG. 3L illustrates a submerged underwater generation system **690**; an integrated modular ducted **615** turbine-generator **611** with nacelle; combined with a variant submerged self-regulating ballast tank **578ax**. Enabling turbine-generator **611** to be buoyancy neutral. The walls of tank **578ax** acts as a duct **615**; hood **615**; or housing **615**; making the turbine-generator system **611** a confined space for the extraction and direct conversion of kinetic energy of tidal stream; to mechanical energy; and electrical energy. FIG. 3K illustrates the sectional side view; while FIG. 3L illustrates the sectional rear view **3L-3L** of ballast tank **578ax** and turbine generator **611**. The upper portion (cavity **676**) of the tank **578ax** may be filled up with air **683** while the bottom portion contains water **681**. The apparatus may be supported by line **295ax**; underwater cable **457ax** secured to surface buoy mooring **508ax**. Buoyancy may be maintained by means of automated sub-system **686**; enabling ballasting and de-ballasting of the cavity **676**. Ballasting may be done by bleeding off excess air; and allowing water to enter to flood the cavity **676**. While de-ballasting may be done by topping up air from an air cylinder **203ax**; and expelling ballast water **681** from the cavity **676**. Buoyancy of the apparatus being automatically maintained by means of an artificial intelligence (AI) computerized module **677**; air lines **204ax**; compressed air cylinder **203ax**; and twin sets of 3-way valves **678**; **679**.

Ballast water may be controlled by 3-way valve **678**; while pressurized air may be controlled by 3-way valve **679**; by means of control signals from computerized module **677**. To increase buoyancy and reduce ballast: water control valve **678** opens its bleeder port **678e** to dispel water **681** from cavity **676** via tubing **682**. At the same time air control valve **679** opens its air supply port **679s** to pressurize cavity **676**. Air **683** from cylinder **203ax** enters cavity **676** from valve **679s** via tubing **684**; displacing water via port **678e**. To reduce buoyancy and increase ballast: the reverse is true. Valve **678** opens its supply port **678s** to take in ballast water **681**; while valve **679** opens its bleeder port **679e** to expel air **683** from cavity **676**. Water enters cavity **676** via valve **678s**; tubing **682**. Air **683** exits via tubing **684** valve **679e**.

The turbine-generator **471ax** and shaft **475ax** may be kept in position by means of supporting struts **685**. Such a system may impose minimum weight, stress and strain on the surface buoy. The generation elements comprising: rotor magnets **476ax** and rotor wire coils **474ax** mounted at the central shaft **475ax** may be configured to be counter-rotational. Wherein, the center turbine **471bax** may be configured to rotate against the fore turbine **471aax** and aft turbine **471cax**.

FIG. 3M illustrates the sectional view of a helically shaped screw turbine **613** which may be used in the apparatus **611a** of FIG. 1A. The screw turbine may have the

electricity generation elements comprising magnet rings **476ax**; wire coils **474ax** located on the casing surrounding the turbine; instead of at the center as most turbines may be configured. Since the helically shaped screw turbine may be configured securely affixed to the peripheral casing **667** integrated with magnet ring **476ax**; said apparatus does not require a central shaft; but instead comprises entirely of a long length of twisted-turning impeller-turbine blades **613**.

FIG. 4A to FIG. 4I illustrates a variant Split Unit Energy Conversion System **700**; derived from the: (a) "Distributed System for Extraction of Energies from high altitude wind currents and deep sea ocean currents **600ax**"; (b) transmission of extracted energies into an; (c) "utility scale Centralized Power Generation Plant **585**; and counter-rotational generation system **590d**; and **590h**" (refer: FIG. 7A to FIG. 7H; U.S. Ser. No. 15/630,670). These prior art disclosures may be adapted for use in a variant system **700** for harvesting ocean renewable energies comprising: tidal energies and/or offshore wind energies for conversion into electrical energies. Wherein said variant apparatus **700** derived from system **600ax** and counter-rotating generation system **590ax** may comprise of: (a) conversion of the kinetic energies of tidal current stream into mechanical energies by means of a multitude of distributed marine turbines **472ax** (configured without individual nacelles) mounted on the external body **701**; (b) transmission of said mechanical energies by means of a torque transmission system **687** comprising of: flexibly configured shafts **475ax**; gear boxes **583ax**; torque transmission shafts **691**; extended torque transmission shafts **692**; wire-coil transmission gear-wheels **693**; gear **694**; magnet transmission gear-wheels **695**; gear **696**; bearings boxes **586ax**; universal couplings **666**; and other forms of mechanical parts and fittings; to an (c) utility scale Centralized Power Generation Plant **585ax**; **590ax** (a counter-rotating electrical generator) housed inside said turbine-generator body structure **701**. The transmission shafts **691** may also comprise of or may be replaced by: chains and sprockets; belts and pulley wheels; normally used for mechanical torque transmission in industrial machines. Such transmitted mechanical energies may also comprise of wind power generated torque from a plurality of wind turbines **472ax** configured (without individual nacelles) for transmission of mechanical energies created into a Centralized Power Generation Plant **585ax**; or **590ax**. Wherein transmitted torques derived from both wind and tidal powered turbines may be channeled into a centralized counter-rotating generator **590ax** as illustrated in FIG. 5A. An advantage provided by the Distributed System for Extraction of Renewable Energies **600ax**; and the derivative Split Unit Energy Conversion Systems **700**; **740**; etc. of present invention.

Said split unit energy conversion system comprising: distributed renewable energies collection cum extraction system (drive units **51ax**); torque transmission system **687**; and counter-rotational generation system (driven unit **54ax**). Enables the combination; channeling; concentration; congregation of wind and tidal energies derived from: (a) multiple drive units of one type of apparatus (from one system); (b) drive units derived from a myriad; diverse; different types of apparatus (from multiple systems). Transmission of converted mechanical energies by means of a torque transmission system **687**. Into one driven unit **585ax**; **590ax**. Wherein (a) said collective energies in wind and tidal current extracted by means of a distributed network of multiple drive units **51ax** comprising: windbags **30ax**; water-bags **40ax**; drones HAV-**100ax**; HUV-**200ax**; HAV-**400ax**; HAV-**400Max**; windbags **76ax**; water-bags **222ax**;

horizontal axis wind turbines **472ax**; horizontal axis tidal turbines **472ax**; vertical axis wind turbines **477ax**; vertical axis tidal turbines **477ax**; etc. (b) may be transmitted by means of an inter-connected network **687** of turbine shafts **475ax**; transmission shafts **691**; extended shafts **692**; **595ax**; gears and gearboxes **583ax**; bearing boxes **586ax**; and structural support **599ax**; etc. inter-linked to form a mechanical energy (torque) transmission system **687**; for (c) powering a combined driven unit **54ax** comprising counter-rotational generator **585ax**; or **590ax**.

Wherein, said generation system (driven unit **54ax**) **585ax**; **590ax**; may be suitably configured for the conversion of concentrated mechanical energies transmitted from a plurality; a multitude; a myriad; an aggregation comprising: thousands of individual drive units; different types of (wind and tidal powered drive units **51ax**). Said mechanical energy (torque) conveyed by means of a distributed network; a torque transmission system **687**. Wherein, said variety of different types of drive units **51ax** comprises: horizontal axis wind turbines **472ax**; horizontal axis tidal-turbines **472ax**; vertical axis wind turbines **477ax**; vertical axis tidal-turbines **477ax**; drones HAV-**100ax**; HUV-**200ax**; HAV-**400ax**; HAV-**400Max**; multiple windbags system **76ax**; multiple waterbags system **222ax**; etc. Wherein, said torque transmission system **687** comprises: (a) shafts **691**; extended shafts **692**; **595ax**; gear boxes **583ax**; gear-wheels **693**; **694**; **695**; **696**; (b) line reels **582ax**; **582ax"**; transmission lines **591ax** system; (c) dual line reel drums **582ax** cum **588ax** with transmission lines **591ax** protected by hard cover **592ax**; (d) sprockets **738**; **739** and roller chains **742** system; (e) pulleys wheels **743**; **744** and belts **746** system; (f) bendable universal couplings **666** used for flexible transmission of angular torque.

Wherein, said multitude of drive units **51ax** does not require individual nacelles **611**. As the kinetic energies of wind and tidal extracted by said multitude of individual drive units **51ax**; and converted into mechanical torque; may be transmitted by means of torque transmission system **687**; and combined together into one common generation unit **585ax**; **590ax**.

FIG. 4A illustrates system **700**; an individual unit of split-unit turbine-generator **700** configured with a watertight body **701** for underwater operations. Wherein said split-unit energy conversion system **700** may be configured with means comprising: (1) a distributed network of hydro-turbine units **472ax** (drive units) spread out all over the skin of turbine-generator body **701**; (2) interconnected by means of a mechanical energy and/or torque transmission system **687**; (3) to a driven unit comprising centralized counter-rotating electrical generator **585ax**; **590ax** housed inside said body **701**. Wherein, the kinetic energies extracted from tidal current (kinetic to mechanical energy conversion) by means of multiple drive units (e.g. 100; 500; 1,000 units of marine hydro-turbines **472ax**); may be transmitted; to power one single driven unit (generator **590ax**) for conversion into electricity. The structural body **701** of split unit turbine-generator **700** may be moored to surface buoys **508ax**; ballast tanks **578ax**; pontoons **734**; surface ships **659**; by means of mooring lines **512ax**; and anchored to the seabed **537ax** by means of anchoring lines **295ax**. Electrical power transmission lines **457ax** routes generated power from the power off-take point **688**; to the surface based sub-stations **622**; transformers **622**; rectifiers **622**; hydrogen electrolyzer plants **509ax**. FIG. 4B illustrates the cross-sectional and perspective view **4B-4B** of system **700** wherein one specific body **701** section may be configured with four units of large hydro-turbines **472ax**. FIG. 4C illustrates a variant configu-

ration of FIG. 4B wherein said turbine-generator body **701** may be configured with eight smaller units of hydro-turbines **472ax** on one specific section of its body **701**. Any number of marine turbine units **472ax**: 4, 6, 8, 10, 12, etc. may be arranged on one section of body **701**. Wherein, dependent upon the configured length of said turbine-generator's body **701** (and that of the central generator **585ax**); for example: 100 meters; 500 meters; 1 km; 2 km; etc. The total number of tidal turbines **472ax** configured may be: 100 units; 500 units; 1,000 units; 2,000 units; etc. All said drive units linked to; powering one central generation (driven) unit **585ax**; **590ax**. Or, for practicable purposes such as torque transmission; said generation unit **585ax** may be sub-divided into a few sections: **585ax'**; **585ax"**; **585ax'"**; etc. For example: 100 or 200 turbine **472ax** units may be assigned to drive one section **585ax'** of generation unit **585ax**. Likewise, for example: if one extended shaft **692** is configured to transmit the mechanical torque from units of turbines **472ax**. The combined energies from 100 turbines concentrated in 10 extended shafts **692** may be used to power one section **585ax'** of generation unit **585ax**. Five units of shafts **692** may be configured to power the rotor magnets **476ax** clockwise; the other 5 units of shafts **692** configured to power the rotor coils **474ax** anti-clockwise. If each hydro-turbine unit **472ax** is configured to produce, for example: one megawatts of rated power. Said turbine-generator **700** may be configured to produce: 100 MW; 500 MW; 1,000 MW; 2,000 MW; etc. Wherein, an array comprising a multitude of such turbine-generators **700** configured in an ocean renewable energies farm **710** of FIG. 4D; and FIG. 5J to FIG. 5L may be designed to produce multiple Gigawatts of power for provisioning cities; island states; nations; etc. A combined seaborne: wind; tidal (water current); solar; energies production complex **300ax**; cum processing plant for conversion of renewable energies to clean electricity; or optionally, into a clean energy carrier, hydrogen. An ocean renewable energies ecosystem **300ax** configured for 100% renewables.

Engaging with the tidal current, marine hydro-turbines **472ax** transforms the tidal stream's inherent kinetic energy into mechanical energy. This mechanical energy is in turn transmitted by means of a torque transmission system **687** comprising a plurality of: (externally located) turbine shafts **475ax**; torque transmission gear-boxes **583ax** inside housing **473ax**; drive shafts **691** inside housing **592ax**; to (internally located) gear-boxes **583ax**; long extended shafts **692**; gears **694**; **696**; gear-wheels **693**; **695**; supported by bearing boxes **586ax**; directly engaged with the generating elements **474ax**; **476ax** of central generator **590ax**. Turbine-generator module **700** may be configured with a very long centralized generator **585ax**; or **590ax** located in the middle of its body **701**; running its entire body length; from bow to stern; from fore to aft; for example: 100 meters; 500 meters; 1 km; 2 km; etc. Generating elements comprising: rotor wire-coils **474ax**; rotor magnets **476ax**; may be configured to rotate in opposite directions to each other. Both the rotor wire-coils **474ax** and rotor magnets **476ax** may be configured to interact; and be directly engaged with the torque transmission system comprising: shafts **691**; gear boxes **583ax**; gear-wheels **693**; **695**; etc. Said gears; gear-wheels and gearbox **693**; **694**; **695**; **696**; **583ax**; etc. may also comprise of: step-up and/or step-down gear-shifts cum transmission mechanisms; configurably responsive to external tidal stream conditions. Optionally shaft **691** protected by housing **592ax** may be configured flexibly attached to body **701**; wherein, said shaft **691** (slotted in or out) may be affixed to or detached from the (pre-configured connection such as flanges) short mounting stubs **698** on body **701** by means of twin "C-C" clamps **665**.

The rotor wire-coils **474ax** may be driven by means of gear-wheels **693**; which engages with gear **694**; borne by extended shaft **692** which transmits the torque from multiple drive units **472ax**. The rotor magnets **476ax** (located in the middle of generator **590ax**) may be driven by means of gear-wheels **695**; which engages with gear **696**; at the fore and aft (front and back ends) of generator **590ax**. Structurally the rotor wire-coil **474ax** of the long generator **590ax**; extending from bow to stern; may be configured for provision of suitable access space **697** enabling gear-wheel **695** attached to rotor magnets **476ax** to engage with torque transmission gear-wheel **696**. Wherein rotor wire-coil **474ax** may be divided into a couple of sub-sections. Thus enabling said gear-wheel **695**; attached to rotor magnets **476ax** to project beyond the external diameter of the rotor wire-coils **474ax** (generator body); thus engaging with gear-wheel **696** borne by the extended shaft **692** which transmits the torque from drive units **472ax**. Optionally gear-wheel **696** may project into gap **697** to engage with gear-wheel **695**. Such an arrangement enables the configuration of individual generation elements comprising: rotor wire-coils **474ax**; and rotor magnets **476ax** to revolve; or rotate opposite to each other. Wherein, motive velocities of the counter-rotating generation elements relative to each other may be doubled. Such a structural configuration may be transformed into improved productivity and efficiency. Variant generation system **777** of FIG. **6F** may also be adapted for use.

Fifty percent (50%) of the total drive units comprising marine-turbines **472ax** may be configured linked up to drive the external rotor wire-coils **474ax**; while the other half of the hydro-turbines **472ax** may be configured engaged with, to power the internally located rotor magnets **476ax**; wherein both the external and internal generation mechanisms may be driven by said torque transmission system; and may configurably be rotated in a direction opposite to each other. Such a counter-rotating generator **585ax**; **590ax** securely mounted inside turbine-generator body **701**; driven by a distributed network comprising hundreds of drive units **472ax** spread out all over the external skin/or body **701** of turbine-generator **700**; interconnected by means of a torque transmission system; said combined energies channeled into said single generator **590ax**. May provide a more cost-effective means of generation than the present system of incorporating expensive individual nacelles for each and every hydro-turbine **471ax**. Even though integrated direct drive cum conversion apparatus **471ax** serves their purpose well. It may be cheaper to design and easier to construct one single generator body **701** containing; in this case, a very long generator **585ax**; **590ax**. Said body **701** housing generator **585ax**; **590ax** configured with water-tight seals; water-proofed; leak-resistant; in particular interconnecting joints; points where the plurality of transmission shafts **691** enters housing body **701**. Other externally located equipment and fittings comprising: turbines **472ax**; shafts **475ax**; gear-boxes **583ax**; housing **473ax**; transmission shafts **691**; casing **592ax**; etc. may also be sealed and water proofed. Optionally, they may not require any water proofing if the components are; configurably made of compatible materials tolerant of sea water such as: ceramics; composites; plasticized components. And if practicable all of these externally located energy conversion components may be designed and configured to use the surrounding sea water as a lubricant and coolant. Wherein free flowing sea water; or pumped sea water may be used in these components for lubrication; and as a cooling medium. Such a sea-water based cooling system may comprise of: a plurality of cooling fins **699** installed inside body **701**; a pressurized piped **702** distribution system

supplied by a pump; providing cooling for the centralized generation system inside body **701**. Said pressurized sea water may also be piped to lubricate moving joints; gears; etc. The portion of shaft **691** at the point of connection to/with the body **701** requires sealing; leak proofing and configured to be water tight; including the whole turbine-generator body **701**. Such a concept differs from the current practice of configuring integrated direct drive turbine-generator units in which each and every individual nacelle requires leak-proof; water-tight construction; leading to high production costs.

Optionally, turbine-generator body **701** may be positively pressurized with air; nitrogen or CO<sub>2</sub> gas; and the internal pressure remotely monitored; equipped with low pressure alarms. Compressed air cylinders; air-lines **638** extending from surface buoys **508ax** and ballast vessels **509ax** to an air operated pump **637** located inside body **701**; may also be configured for automated topping-up purposes. Such a design ensures a water-tight seal of the entire body **701**. In case a leak develop, air will leak out from the body **701**; not water entering into body **701**. Control surfaces comprising hydroplanes **205ax**; **207ax**; **208ax**; may be configured on the external of body **701** for body balancing and control. Internal body **701** space including empty space **689** located fore and aft may provide some buoyancy. However due to the mass; quantity and heavy weight of hundreds; or thousands of tidal turbines **472ax** it is carrying, body **701** may not have sufficient buoyancy to stay in position underwater. External ballast tanks **578ax** with automated artificial intelligence (AI) **677** buoyancy control sub-system **686** may be used to achieve neutral buoyancy enabling body **701** to stay suspended in a relatively stable position in the water. Floatation collar bags **714** may be affixed fore and aft of body **701**; inflated to provide additional buoyancy; or deflated as and when required by means of: UUV-**230ax**; UUTV-**230ax**; submersible boats **220ax**; PSV-**220ax**; equipped with robotic appendages **522**; air cylinders **203ax**; etc.

Optionally, if deemed desirable and advantageous, the drive components for said above energy conversion system **700** may also be configured with standard units of integrated direct-drive turbine-generation with nacelles **611**; **471ax** (refer FIG. 4A U.S. Ser. No. 15/630,670) widely used in the marine renewable energy (wind and tidal current) extraction industry currently. Standard rotor-stator generators may also be used in lieu of centralized counter-rotating generators **585ax**; **590ax** mounted inside body **701**.

Surface based supporting components of system **700** may comprise: boats **659**; ships **741**; outriggers **747**; pontoons **734**; buoys **508ax** and ballast tanks **578ax**; with automated ballast control systems **686**; secured to seabed **537ax** by means of mooring lines **295ax**; buoy **508ax** mounted reels **52ax** bearing transmission lines **457ax** and mooring lines **295ax**; connected to turbine-generator body **700**; sensitive and delicate electrical components such as rectifiers **622**; transformers **622**; sub-station **622**; and hydrogen electrolyzer plants **509ax** securely housed in buildings mounted on floating ballast vessels **578ax**; solar panels **579ax** on rooftops. Including split unit wind turbine system comprising: turbines **472ax**; gearbox **583ax**; mounted on vertical pillars **469ax**; with extended shaft **595ax**; generator **54ax**. Or, optionally said turbines **472ax**; gearbox **583ax**; may be mounted on extended hydraulic booms **619**; with extended shaft **595ax**; generator **54ax**. Other apparatus may comprise: integrated direct drive vertical-axis wind turbines **477vax** units supported by vertically disposed pillars **618**; or standard vertical-axis wind turbines **477ax** units. A hydrogen plant comprising: electrolyzer modules **509ax**; hydrogen-

ammonia storage tanks **704**; piping; pump; etc. may be built on a floating surface platform interconnected by means of beams **652**; floor structure **715**; gratings **703**; etc. Hydrogen produced by the floating plant may be absorbed into liquid ammonia and stored in tanks **704**. Liquid ammonia had a very high compatibility and affinity for absorbing hydrogen; and may be used as a carrier. Wherein, said liquid ammonia carrier may be handled, pumped, transferred in pipes; between storage tanks; tankers; terminals; end-user points; etc. by means of an existing global infrastructure used in handling ammonia. Reconversion from said carrier by means of metal membranes (CSIRO developed technology) into hydrogen gas may be carried out at the end-user points; and processed for sale to customers; etc. Underwater components may comprise powerful variants of drones UUTV-**230ax**; manned personal submersible vehicles PSV-**220ax** for patrol-checking; monitoring; working as submersible tug-boats; pilots; towing, maneuvering turbine-generator **700** into desired positions. Customized mother ships **730** for servicing and repair of system **700** may comprise of vessels with a catamaran hull structure; wherein, said apparatus **700** may be suitably and safely brought into dry dock repair conditions by means of customized equipment that only a twin hulled vessel may be well suited to provide.

Split unit turbines-generator system **700** may be configured as an independent unit, or integrated into an energy extraction farm environment **710**. Means of propulsion may comprise: a plurality of unmanned underwater tug vehicles UUTVs-**230ax**; or manned personal submersible vehicles PSV-**220ax**; manned submersible boats **220ax**; flexibly attached to a plurality of traction apparatus **705**; traction poles **705**; adapted with customized traction pads **706**; used mainly for linear maneuvering and side-ways movement and fine tuning of body **701** position. Flexibly attached to designated traction pads **706**, a plurality of UUTV-**230ax** may also be used as submersible tugs for navigation of turbine-generator **700**. UUTV-**230ax** may be detached once the turbines-generator **700** had been anchored by means of mooring lines **512ax**; **295ax**; hooked gripping apparatus **711**; hydraulic clamping apparatus **712**. Control surfaces and hydroplanes **205ax**; **206ax**; **207ax**; **208ax**; may be used to align body **701** with the tidal current flow. As and when required collar ring airbags cum floats **714** may be flexibly attached to the fore and aft body portions of turbines-generator **700** by means of: submersible boats **220ax**; UUTV-**230ax**; PSV-**220ax**; mounted with robotic arms **522ax**; or robotic appendages **522ax**. Apparatus **714** inflated by means of compressed air from cylinders **203ax**; provides additional buoyancy for lifting the body **701** to the surface. The buoyancy of external ballast tanks **578ax** may also be adjusted and maximized.

FIG. 4B illustrates details of Section 4B-4B configured with four large turbines **472ax**; gearbox **583ax**; mounted on shafts **691** in housing **592ax**. FIG. 4C illustrates a variant configuration of FIG. 4B wherein eight smaller turbines **472ax** may be configured on the skin of turbines-generator body **701**. The circle **707** around turbine **472ax** indicates the turbine blades swept area. Shaft **691** connects the external turbine unit **472ax** to the internally located shafts **692**; transmission gearboxes **583ax** and other torque transmission mechanisms **693**; **694**; **695**; **696**; kept housed inside the water-tight body **701**. Generating components comprising: rotor wire coils **474ax** surrounding a central shaft **581ax** integrated with rotor magnet core **476ax**; lubrication system; cooling system **699**; **702**; and other auxiliary equipment are housed inside sealed body **701**. Generator **585ax**; or **590ax** may be configured running the entire length of the tidal;

marine-hydro-turbine-generator **700**; wherein said body **701** may be configured anywhere from: 100 m to 1 km long; bristling with 1,000 to 2,000 units of marine tidal turbines **472ax**. For the purpose of torque transmission, the long generator **590ax** (running the entire length of body **701** from fore to aft) may be configured with a few sub-sections. Each individual sub-section of generator **590ax** may be configured to be driven; powered by 100 units; 200 units; etc. of marine turbines **472ax**. External body **701** may be configured with a plurality of traction poles **705** providing docking ports **706** for drones UUTV-**230ax** to pilot and navigate apparatus **700**. UUV-**220ax** or PSV-**220ax** may also be used alongside UUTV-**230ax**. External ballast tank or vessel **578ax** flexibly mounted onto traction pole **705** may be adjusted to attain neutral buoyancy for system **700**; enabling it to remain suspended at various depths in the water column. Automated buoyancy control sub-system **686** disclosed in FIG. 3K to FIG. 3L; by means of a computerized artificial intelligence (AI) module **677** may be used for maintaining the neutral buoyancy of turbine-generator **700**.

FIG. 4D and FIG. 4E illustrates a farm configuration wherein a multitude comprising hundreds of turbine-generators **700** may be configured; systematically deployed; and securely anchored in an ocean renewable energy extraction plant **710**; an energy conversion farm **710**; or an energy generation park **710**. Forming another component of Renewable Energies Conversion Complex **300ax**. FIG. 4D illustrates the side view; while FIG. 4E illustrates a plan view of ocean energy conversion plant **710** (wherein concrete flooring **715** may be assumed to be transparent). A planned array, an ocean renewable energies conversion complex **710**; stretching kilometers square in area; covering kilometers cube in volume. Wherein, rows upon rows; layers upon layers; a multitude comprising hundreds; or thousands of turbine-generator units **700** may be arranged horizontally; and stacked one on top of another in the vertical water column; rising from the seabed **537ax** to the sea surface **621**. Each unit optimally spaced from the adjacent neighboring unit. Systematically harvesting; harnessing; extracting tidal stream energies of the ocean; including offshore wind and solar; for conversion into multi-Giga-watts of useful energies for human consumption.

Ocean energy conversion plant **710** may be configured with a plurality of large customized heavy-duty pillars **708**; or columns **708**; affixed securely into the seabed **537ax** by means of deep-sea piles **562ax**; drilling pipes **651**; and reinforced concrete slabs **653**. Specially configured for use in the plant **710**; pillars **708** and columns **708** may be adapted with slots **709**; for installing: (a) mooring lines **512ax**; pulley wheels **629**; roller wheels **629**; motorized **639** winch powered line reels **52ax**; (b) hooked gripping apparatus **711**; and (c) a plurality of hydraulic clamps **712** for gripping tightly onto body **701**. A plurality of reinforced concrete floor **715**; or levels **715** built atop said plurality of columns **708** may be used for mounting supporting equipment. Turbine-generator **700** may be parked in its designated slot **709** by means of such apparatus **711**; **712**; released to surface for servicing and repair works; and re-installation back into its designated slot without interfering in the operation of any other neighboring unit in the plant.

FIG. 4F illustrates a sectional side view; while FIG. 4G illustrates a perspective view of FIG. 4F showing the working mechanisms of anchoring apparatus **711**. Sub-system **711** may be securely affixed into customized slots **709** configured into main pillars **708**. Slots **709** may be configured to accommodate a mooring line **512ax** held securely in reel drum **52ax** mounted on the reinforced concrete floor **715**

above. Passing through a plurality of motorized winch **639**; pulley wheels **629**; pulley roller-bars **629**; line **512ax** may be attached to nose-ring **716** on the fore nose-cone of turbine-generator body **701**. Apparatus **711** may be configured with a plurality of gripping hooks **717**. Gripping hooks **717** may be flexibly and securely attached to collar ring **718** configured on the neck of turbine-generator body **701**; or opened up to release its grip. Gripping hooks **717** may be mounted in pneumatic or hydraulic operated holders **720**. Optionally, gripping hooks **717** may be mounted in like hydraulic holders **720** residing inside of the main body **721**. Said holders **720** configured with traction pads **719** at its points of contact with body **701**; may be configured to operate; extending from and retracting back into the structural mounting body **721** of apparatus **711**. Holders **720** may also be configured to move the plurality of grippers **717** outwards, towards the periphery; or moving them inward, towards the center. Thus “opening” and/or “closing” its gaping “mouth”. Opening them up to enable gripping of collar ring **718**; or for release from collar ring **718**. Closing them in order to grasp; gripping tightly onto collar ring **718**; holding body **701** in place. Grippers **717** may also be extended (longer) or retracted back (shorter) into holder **720**. Said plurality of holders **720**; grippers **717**; and mooring line **512** moved by motorized winch **639** of line reel **52ax** may be configured operably working in tandem with each other. Said ocean renewable energy conversion plant may be remotely controlled; monitored; coordinated; by means of: cameras; active and passive sensors; etc. Active use of aerial and underwater drones: UUV-**230ax**; manned PSV-**230**; etc. Providing instantaneous; interactive control of plant process and equipment.

For docking of turbine-generator unit **700** into assigned slots **709** of columns **708** the following sequence of maneuvers may be executed. Holders **720** may be operated to open up fully (larger gap between traction pads **719**); grippers **717** fully open, extended outward. Mooring line **512** pulled taut by motorized winch **639** of line reel **52ax**; may be pulled to move slightly towards holders **720**. Grippers **717** may be moved into closed position; extending beyond the ring **718**; touching the skin of body **701**. The length of the gripping hooks **717** may then be adjusted; its length may be firstly minimized; and then extended to 50% of its total length; and then locked in position; gripping onto extended collar ring **718** configured around the “neck” of body **701**. Length of line **512ax** may be slightly released and then pulled taut; adjusted into optimized position. Holders **720** may be adjusted holding the nose-cone of body **701** in place. The plurality of body clamps **712** located on the fore and aft pillars **708** may then be activated to clamp tightly onto body **701**. Multiple units of manned PSV-**230ax**; UUTV-**230ax** underwater tug vessels attached onto docking pads **706** of traction poles **705** and used to propel turbine-generator unit **700** may now be decoupled from docking pads **706**. Collar airbags **714** affixed on the fore and aft of body **701** for buoyancy may now be depressurized; detached and removed by UUTV-**230ax** mounted robotic appendages **522ax**.

For undocking of turbine-generator unit **700** from slots **709** of columns **708** the following sequence of maneuvers may be executed. Collar ringed airbag **714** may be securely attached to fore and aft of body **701**; airbags **714** may also be affixed onto traction pole **705** by manned PSV-**230ax** or UUTV-**230ax**; then inflated by means of compressed air from cylinders **203ax**; providing adequate buoyancy for unit **700** to float. The plurality of body clamps **712** may be deactivated and opened up; holders **720** opened up; mooring line **512** pulled taut; moving the body **701** slightly forward;

loosening it from the tight grip of grippers **717**. Then the grippers **717** may be opened up, moving outward, releasing its hold on collar ring **718**; and thus body **701**. Line **512** may then be controllably released by motorized winch **639** of line reel **52ax**. Allowing turbine-generator **700** to move aft naturally by means of tidal current flow. UUTV-**230ax**; manned PSV-**230ax** may be used for side way steering and adjustments to prevent body **701** or turbines **472ax** from coming into contact with neighboring units.

FIG. 4H illustrates a sectional view 4H-4H showing the plurality of anchoring hooks **717** holding securely on to the extended rim of collar ring **718** configured on the neck of the body **701** of turbine-generator **700**. FIG. 4I illustrates the working mechanisms of clamping apparatus **712**. Configured as an encircling clamp, a plurality of pneumatic or hydraulic operated holders **722** with clamp pads **713** may be used. Wherein said plurality of holders **722** with clamping pads **713**, once activated; held tightly onto the external skin of turbines-generator body **701**. Providing a strangle hold on turbine-generator **700**. The hydraulic system used to operate the holders **722** may reside in the body of apparatus **712**. It may also be supported by equipment kept on floor **715** above. Apparatus **712** for the aft; pillar **708** located at the stern of body **701**; may comprise of a standard two piece clamping apparatus operated by means of like hydraulic mechanisms **722** and clamp pads **713**. Bringing the semi-circular bodies of the twin pieces of half-clamps together enables the apparatus to grip tightly onto the aft portion of body **701**; while opening up the twin pieces of half-clamps releases its hold on the aft portion of body **701**.

Optionally, the bow portion of turbine-generator body **701** may be modified as illustrated by a unit **700** nearest to the seabed **537ax** in FIG. 4D. The nose cone (next to nose ring **716**) portion may be miniaturized and made much smaller; instead of being the same size as the body **701**. Similarly components of customized apparatus **711** and **712** may be reconfigured to suit such a modification. In one form the nose cone may comprise of a narrow flattened arrow-head-like piece with collar plates **718'** sticking out of both the upper and lower surfaces. Such that the anchoring apparatus need not be configured or constructed large. But configured to be smaller, stronger, thicker and much more robust structurally.

Turbine-generator units **700** may also be deployed in a system of free floating bodies **700** suspended at various depths; spread out in the ocean as illustrated in FIG. 5K to FIG. 5L; enabled by means of a network of anchoring lines **295ax**. One end of said lines **295ax** may be anchored to the seabed **537ax** by means of anchoring system **650** and **660**; the other end supported by means of floating surface platform comprising: ships **741**; catamarans **747**; pontoons **734**; ballast vessels **578ax**; mooring buoys **508ax**. Enabling systematic extraction of tidal energies from the bottom of the water column **537ax** right up to the top **621** of the water surface.

FIG. 4J and FIG. 4K illustrates the sectional views of a customized ballast vessel **730**; specially configured for on-site servicing and minor repairs of underwater turbine-generators **700** in dry docks condition. Ballast vessel **730** may be configured with a split body structure comprising an integrated catamaran-crane-ballast vessel with ballast tanks **723**; **724**; **725**; at the fore portion to submerge/float as required. While the aft portion comprises a (static and fixed) ship's body. Wherein said fore and aft joining point may be configured with a plurality of vertically disposed I-beams; and C-shaped outer sleeves. Upon which said flexibly connected fore portion may slide up and down said I-beams; by

means of C-shaped outer sliding sleeves mounted onto said I-beams; as it operably submerges underwater; or float buoyantly as configured. Wherein the fore catamaran's body portion may be configured to operate independently of the ship's body. The fore portion may be held together by means of a plurality of pneumatic or hydraulic jacks and booms 619; and overhead cranes 727; attached to structural frame 728. Jacks and booms 619 may be lowered (FIG. 4J) to open up the front "inlet port" engulfing apparatus 700; or raised (FIG. 4K) to constrict said inlet port; extended or collapsed to lift or lower the load. Such that said catamaran's body may be operably submerged underwater; to capture the semi-submerged turbine-generator 700 with its body; secure apparatus 700 by means of restraining bars and hydraulic arms 729; constricting its twin catamaran (723; 724; 725) bodies like a pair of giant pincers; grasping and holding onto apparatus 700. Engulfing; embracing the whole apparatus 700 with its ballast body. Apparatus 700 may then be lifted upwards by means of a plurality of lifting cables 731 (fore; middle; aft sections of apparatus 700) attached to lifting lugs 732; motorized 733 overhead cranes 727. At the same time, the body of the catamaran may be lifted upwards by means of inflating variable ballast tank 724 with compressed air; creating the required buoyancy. Located at the middle portion of the catamaran's body, tank 724 may be collapsed, shrunken and constricted by deflation (FIG. 4J). It may be extended and blown up like a balloon by means of compressed air (FIG. 4K). The top 723 and bottom 725 portions of ballast tanks may be fixed in shape and buoyancy. Morphing ballast tanks 724 may be made of durable and pliable materials comprising: plastics; composites; rubber; synthetics; etc. The booms 619 carrying overhead crane 727 may then, be extended upwards to lift apparatus 700 higher up; out of the water. Restraining bar and hydraulic arm 729 may be moved higher up; then secured in position. Hydraulic jacks 619' may be used to prop up traction poles 705 holding apparatus 700 in a fixed position. Maintenance work may then be carried out in dry dock conditions.

FIG. 5A illustrates split unit generation system 740; a variant version of the underwater system 700 as disclosed in FIG. 4. System 740 comprises a surface based floating platform 740; integrating different drive units from both wind and water current: offshore wind turbines 472ax; tidal turbines 472ax; etc. Wherein the external body and skin comprising: deck 736; hull 737; of a ship 741; may be configured with a multitude of drive units comprising: horizontal axis wind turbines 472ax; horizontal axis hydro-turbines 472ax; vertical axis wind turbines 477ax; vertical axis hydro-turbines 477ax; drones HAV-100ax; HUV-200ax; HAV-400ax; multiple windbags system 76ax; multiple water-bags system 222ax; etc. These drive units may be configured and used for the extraction, conversion and transformation of ocean renewable energies derived from offshore wind and tidal streams (water currents). The energies extracted by said drive units may be transmitted by means of torque transmission systems 687; to the generating elements 474ax; 476ax of central generator 585ax; 590ax; located in the middle, at the center of the ship's body 741; running its entire body length; from bow to stern; from fore to aft. Said torque transmission systems 687 may comprise: (a) turbine shafts 475ax; 691; extended shafts 692; 595ax; gear boxes 583ax; gear-wheels 693; 694; 695; 696; bearing boxes 586ax and structural support 599ax; (b) line reels 582ax; 582"ax; and transmission lines 591ax system; (c) dual line-reel drums 582ax cum 588ax with transmission lines 591ax protected by external cover 592ax; (d) sprockets 738; 739 and roller chains 742 system; (e) pulleys wheels

743; 744 and pulley belts 746 system; (f) bendable universal couplings 666 used for flexible transmission of angular torque; etc. In order to take advantage of the surface platform's (ship) uniquely large super-structure in terms of space; surface area and volume; additional generation modules may also be configured. This may include a plurality of like secondary generators 585ax'; 585ax"; located at both the port and starboard sides; as illustrated in FIG. 5B; including small individual driven units 55ax.

Wherein a split unit turbine-generation system 740 may be configured in which: (1) the collective energies in offshore wind and tidal stream extracted by means of a distributed network of drive units comprising: (1a) a plurality; a multitude of one type of drive unit (51ax); (1b) a plurality; a multitude of different types of drive units (51ax) such as: windbags 30ax; water-bags 40ax; horizontal axis wind and tidal turbines 472ax; vertical axis wind and tidal turbines 472ax; drones HAV-100ax; HUV-200ax; HAV-400ax; windbags 76ax; water-bags 222ax; vertical axis wind turbines 477ax; vertical axis tidal turbines 477ax; etc. (2) may be transmitted by means of an inter-connected network of turbine shafts 475ax; transmission shafts 691; extended shafts 692; 595ax; gears and gearboxes 583ax; bearing boxes 586ax; and structural support 599ax; etc. inter-linked to form a mechanical energy (torque) transmission system 687; for (3) powering a combined driven unit (54ax) such as 585ax; or 590ax. Wherein: said drive units comprising hundreds (or thousands) of individual units of (1a) one type; (1b) a variety of different types such as: wind turbines; tidal turbines; drones HAV-100ax; HUV-200ax; HAV-400ax; windbags 76ax; water-bags 222ax; etc. may be spread out all over the exterior, extending from the skin of said structural body 741 of the ship into the surrounding ocean environment in all directions; into the sky high above; into the ocean deep below; alike the tentacles of a hydra. All of the above said drive units configured for extracting the ocean renewable energies of wind and water. And transmitting said extracted ocean renewable energies to the driven units 585ax; 590ax; by means of an interconnected network of torque transmission system 687. Said plurality of transmission system 687 may comprise of: (a) shafts 475ax; transmission shafts 691; extended shafts 692; 595ax; gear boxes 583ax; gear-wheels 693; 694; 695; 696; (b) line reels 582ax; 582"ax; and transmission lines 591ax system; (c) dual line reel drums 582ax cum 588ax with transmission lines 591ax protected by a cover 592ax; (d) sprockets 738; 739 and roller chains 742 system; (e) pulleys wheels 743; 744 and belts 746 system; (f) bendable universal couplings 666 for flexible transmission of angular torque; etc. Said driven unit 585ax; 590ax comprises a counter rotating generation system residing inside the belly of said surface platform's structural body 741 (ship). The variant horizontal axis wind turbines used may comprise split units systems with distinct sections comprising: turbines 472ax; torque transmission system 595ax; gearbox 583ax; a combined generator 585ax; 590ax. In one form the extended torque transmission shaft 595ax may be kept inside the hollow cavity of the tall supporting pillar 469ax. In another form a hydraulic or pneumatic boom 619 may be used as a supporting structure for turbine blades 472ax; with the extended torque transmission shaft 595ax kept inside a pliable cover 592ax. Mechanical torque from turbine blades 472ax may be routed by means of gear box 583ax'; extended shaft 595ax; gearbox 583ax"; extended shaft 692; to centralized generator 590ax. Due to its space saving configuration and compatibility with wind blowing from any direction, vertical axis turbines 477ax (refer FIG. 4A of U.S. Ser. No. 15/630,670) supported by pillars 618

may be preferred on the fixed decks 736 of ship body 741. Mechanical torque derived from turbines 477ax may be configured to power centralized generators 585ax; 590ax; by means of extended shafts 692; gearbox 583ax. Or, turbines 477ax may be connected to power the secondary units 585ax; 585ax" housed in the bellies of ship 741. Integrated direct-drive-conversion, vertical axis turbines 477vax (refer FIG. 4I of U.S. Ser. No. 15/630,670) supported by pillars 618 which is self-generating may also be affixed on deck 736. Extended shafts 692 replicates extended shaft 595ax; except that the former is configured as part of the turbine-generator 700 system.

Said turbine-generator system 740 comprises a split unit energies extraction; transmission and conversion (electricity generation) system wherein; said driven unit 585ax; 590ax is specially configured for; and capable of being powered (propelled; driven) by means of a multitude of drive units comprising: (a) multiple apparatus of one type, for example: horizontal axis tidal turbines; or (b) multiple apparatus derived from a variety; different types of drive units such as, for example: horizontal axis wind turbines 472ax; tidal turbines 472ax; vertical axis wind turbines 472ax; vertical axis tidal turbines 472ax; windbags 30ax; water-bags 40ax; bagged power generation systems 76ax; 222ax; HAV-400ax; HAV-100ax; HUV-200ax. Said multiple drive units being actively engaged with the ambient wind and tidal currents; in extracting their energies; having a variety of different loads; velocities; tensional forces; directional orientations; etc. for conversion preferably into electricity. An amalgamation, a combination wherein the kinetic energies of wind and tidal currents extracted by means of said variety of different types of drive units comprising: wind turbines 472ax; tidal turbines 472ax; vertical axis turbines 477ax; HAV-100ax; HUV-200ax; multiple water-bags 222ax; multiple windbags 76ax; HAV-400ax; etc. may be transmitted by means of a torque transmission system to; one single driven unit. And used to power, propel (drive) said driven unit 585ax; 590ax. Automated step-up and/or step-down transmission gears; gear-boxes; may be used to provide uniform transmission speeds desirable for the seamless functioning of said generators. Clutch box apparatus 587ax (refer FIG. 7B to FIG. 7D of U.S. Ser. No. 15/630,670) may also be suitably configured for use with the main generation shaft 581ax; gearboxes 583ax; and bearing boxes 586ax. Apparatus 587ax may also be integrated with customized gearbox 583ax into a single unit. Said split unit renewable energy conversion system comprising of: (1) Energy extraction (drive unit 51ax); (2) Torque transmission means 687 (line 50ax; shafts 595ax; 691; 692); (3) Generation unit (driven unit 55ax). Energy conversion being: kinetic energy; to mechanical energy; to electrical energy.

Surface platform system 740 may be configured as an exact replica of system 700 as illustrated in FIG. 4A to FIG. 4C with tidal turbines 472ax. However, it may be desirable to introduce other innovative features in this variant disclosure. Therefore system 740 may replicate system 700, with the exception of two variant configurations comprising: (1) a variety of different drive units may be used to extract wind and tidal energies; and optionally (2) a variant configuration wherein the rotor wire-coil 474ax of generation unit 585ax; or 590ax; may be divided into 3 sections comprising: 585aax; 585bax; 585cax. Wherein the entire inner shaft 581ax cum rotor magnet 476ax of generator 585ax running from fore to aft; from bow to stern; may be configured to be wholly powered by hull 737 mounted tidal turbine units 472ax. Whereas the outer rotor wire-coil 474ax of generator 585ax may be configured; divided into 3 sections compris-

ing: 585aax; 585bax; 585cax. The primary (longest) section 585bax (of the rotor wire-coils 474ax) located in the center may be powered by the plurality of deck 736 mounted wind turbine units 472ax. While the shorter secondary sections 585aax; 585cax of (the rotor wire-coils 474ax) located fore and aft may be connected to and powered by a variety of different drive units comprising: 30ax; 40ax; 76ax; 222ax; HAV-400ax; HAV-100ax; HUV-200ax; 477ax; etc. These numerous distributed drive units may have different configurations; thus producing differing torques; velocities; directional orientation; intermittent generation; etc. that necessitates their partial segregation from the more consistent tidal turbine units 472ax and wind turbine units 472ax; which powered the main generator shaft 581ax comprising rotor magnets 476ax; and rotor wire coils 474ax of primary section 585bax. Thus torque transmitted from drive units 30ax; 40ax; 76ax; 222ax; HAV-400ax; HAV-100ax; HUV-200ax; 477ax; etc. may be configured; assigned to power the rotor wire coils 474ax of secondary sections 585aax and 585cax. Wherein the power produced from secondary sections 585aax and 585cax; may vary and differ from the amount of power produced from main section 585bax, which may be more consistent. Automated transmission gears may be used to provide consistency in torque transmission and shaft revolutions (rpm). Optionally, main generator 585ax may be configured to be wholly powered by wind turbines 472ax and tidal turbines 472ax. Wherein said plurality of split unit sections 585aax; 585bax; 585cax; may be flexibly engaged or disengaged (combined together or segregated) by means of clutch box system 587ax. While torque transmitted from drive units: 30ax; 40ax; 76ax; 222ax; HAV-400ax; HAV-100ax; HUV-200ax; etc. may be routed to secondary generation units 585ax; 585ax"; and small individual generator units 54ax; located port and starboard of production platform 740 as illustrated in FIG. 5B.

Alike system 700; torque derived from the multitude of drive units 472ax may be transmitted by means of system 687 comprising: flexibly configured shafts 475ax; gear boxes 583ax; torque transmission shafts 691; extended torque transmission shafts 692; 595ax; wire-coil transmission gear-wheels 693; gears 694; magnet transmission gear-wheels 695; gears 696; bearings boxes 586ax cum structural support 599ax; universal couplings 666; and other forms of mechanical parts and fittings; to the combined driven units 585ax; 590ax. Bearing boxes 586ax; structural mountings and supports 599ax may be used at the edges of generator components such as: 585aax; 585bax; 585cax.

Advantages of such a split unit configuration comprises: Energies extracted from different sources by means of different types; and a multitude of individual drive units may be transmitted and integrated into a centralized generation unit without affecting the functioning of the entire power generation system. A system flexibly and variably configured to cater for; and to accommodate: (a) a plurality, a multitude of drive units of one singular type; (b) a variety of different types of drive units; distributed at various points in the surroundings; on the land or water surface; submerged at various depths in the ocean; disposed at various heights in the atmosphere. Harvesting, harnessing and extracting the energies of wind and tidal stream; transmitting all of their extracted energies; their combined output (mechanical torque) into one processing point: 585ax. Wherein said concentrated output is absorbed by flexibly configured power generation plant 585ax. Total power produced may vary due to variable ambient conditions.



FIG. 5B illustrates optimized usage of the large space (area; volume) provided by the surface platform 741; wherein main generator 585ax located in the center ran from fore to aft; from bow to stern; hundreds of meters, kilometers in length. Secondary generators 585ax'; 585ax" and small individual units 55ax located port and starboard sides of vessel 741 may also be configured for additional generation capacity. Main generator 585ax; secondary units 585ax'; 585ax" may be kept inside the ship's belly. Smaller individual units 54ax'; 54ax" may be located on deck 736.

FIG. 5C illustrates a variety of different arrangements and structural configuration wherein wind turbines 472ax and tidal turbines 472ax configured outside of a pontoon's body 734; on the deck 736; and hull 737; may be connected with delicate; sensitive electrical generation units 585ax; 590ax kept safely inside its belly; protected and shielded from the extremely rough and corrosive ocean environment. From left to right: a pair of standard wind turbine 472ax and tidal turbine 472ax may be linked together to power generation unit 585aax; by means of extended shafts 595ax; 691. While a quartet of wind turbines 472ax on deck 736 may be paired with a mirror quartet of tidal turbines 472ax on the ship's hull 737 to power generation unit 585bax. The blades of the 4 units of wind turbines 472ax; as well as the 4 units of tidal turbines 472ax may be configured to rotate in the same direction. But their transmitted collective torque may be configured to power the split unit counter-rotational generator 585bax in opposing directions. The quartet of wind turbines may be mounted on a common shaft 475ax supported at both ends by twin pillars 469ax; and configured to orientate to face the wind direction by means of a moveable turntable 745 affixed on to the deck 736. Torque transmitted from the turbines by means of horizontal shaft 475ax; to gearbox 583ax; then to vertical shafts 595ax kept inside pillars 469ax; may be routed to power generator 585bax (mounted beneath turntable 745) by means of a transmission system 687 comprising a plurality of gear-like sprockets 738; 739; and roller chain 742. Optionally it may also be transmitted by means of a mechanism comprising a plurality of pulley wheels 743; 744; and belts 746. The quartet of tidal turbines on the hull transmitted its torque to gearbox 583ax; twin shafts 691; gearbox 583ax; to generation unit 585bax.

Located third from left; a variant pair of counter-rotating wind turbines 472ax (fore and aft) supported by twin pillars 469ax' may also be mounted on a moveable turntable 745' affixed onto the deck 736 (refer: FIG. 4H; U.S. Ser. No. 15/630,670). Transmitted torque from the counter-rotating turbines 472fax; 472aax; by means of horizontal shafts 475ax to vertically extended shafts 595ax' inside pillars 469ax' may be routed by means of gearbox 583ax; pulley-wheels 743; 744; and belts 746 system to power generator 585cax mounted beneath turntable 745'. Or; by means of sprockets 738; 739; and roller-chains 742 mechanism. A similarly configured variant pair of counter-rotating tidal turbine unit 472ax mounted on the hull 737 may be used to power generator 585cax. Another source of electricity generation may be derived from embedded generation components comprising: wire coils 488ax and magnets 489ax embedded into the blades of the twin counter-rotating turbines 472fax and 472aax. Such that when the turbine blades passes each other at high velocity and in close proximity; current may be generated in the embedded generation elements 488ax. Located last from left, an integrated unit of multi-bladed counter-rotating turbine-generator 490ax (refer FIG. 4C to FIG. 4G; U.S. Ser. No. 15/630,670) may be configured on the hull 737. The fore and aft turbines 472ax may be configured to rotate clockwise; powering the cen-

trally located rotor magnet 476ax. While the middle three turbines 472ax may be configured to rotate anti-clockwise; powering peripheral rotor wire coil 474ax located in nacelle 611.

FIG. 5D illustrates commonly used torque transmission system 687 comprising: a sprockets 738; 739; and chains 742 transmission system. It may also be configured as, or comprise of: a widely used pulley-wheels 743; 744; and belts 746 transmission system. These simple mechanisms used the world over may also be adapted for use.

FIG. 5E and FIG. 5F illustrates a variant configuration 740v of system 740 in FIG. 5A to FIG. 5B wherein a turntable platform 745 may be used to address constraints and limitations associated with shifting winds; in the mounting of offshore horizontal axis wind turbine units. FIG. 5E illustrates the plan view; while FIG. 5F illustrates the frontal view of said variant configuration 740v. Normally individual units of integrated wind turbine-generator 471ax mounted on pillars 469ax; or boom 619; may be configured to rotate; re-orientate their turbines 472ax and nacelles responsive to changing wind directions; by means of yaw and pitch control mechanisms. This requires plentiful space around wind turbine units. However, in constricted areas and limited space of a floating platform 740v, where a plurality of wind turbine units 472ax may be configured; turning space is a luxury that is ill afforded. Such constraints may be overcome by configuring said turbines in fixed positions, rendering them incapable of "yaw" response. Instead, the entire platform 745 upon which the turbines are mounted may be configured to "yaw", to be rotated; turned and shifted around like a turntable by means of mechanized systems. Stability may be enhanced by means of a trimaran configuration wherein the main vessel 741 may be supported by twin outriggers 747p; 747s; mounted port and starboard sides connected by horizontal beams 652p; 652s; mounted fore and aft.

A centrally mounted beam or pillar 749 on the body of ship 741 forms the axis upon which turntable platform 745 rotates. Supported by multiple peripheral pillars 751a to 751f; mounted fore; aft; and on the outriggers 747p; 747s. Split unit wind turbines 472ax; extended shaft 692 and a centralized generator 585ax; 590ax may be configured on top of platform 745. Platform 745 rests atop ball bearings 752; and roller bars 752; configured inside "C" channel 753 securely affixed onto the platform's bottom surface. The circular shaped "C" channel 753 configured around the sides of platform 745 embraces flat plates 754 configured around central pillar 749; and affixed on top of side pillars 751a to 751f. Ball bearings and roller-bars 752 located in between the bottom C-channel rail 753 (top surface) and plates 754 (bottom surface) facilitates the turning movement of platform 745. Centralized yaw control system 755 which monitors and detect any changes in wind direction and conditions; may be configured to activate motors 756 powered gears comprising pinions and racks mechanism to move the turntable 745; facing directly into the head wind. A multitude of tidal turbines 472ax configured on the hull 737 of vessel 741 propelled a centralized generator 590ax mounted inside its belly.

Portable tidal turbine units 750 borne by mechanized hydraulic or pneumatic booms 758; and/or arms 758 may be used on the outriggers 747p; 747s; and at the sides of ship 741. The booms 758 may in turn be attached to motorized bodies 757 which supplied the pressurized medium comprising hydraulic fluid or compressed air required to power said booms 758. Motorized bodies 757 houses the hydraulic fluid reservoir and pump; or, compressor and air drums;



hydraulic or pneumatic transmission lines; etc. for powering the apparatus 750. Optionally, a centralized system may be used to supply compressed air or hydraulic fluids for operation. With body 757 used as a supporting structure; and may be securely affixed to the decks 736 of outriggers 747p; 747s; ship 741. For dexterity purposes hydraulic or pneumatic driven booms and arms 758 may be configured to be extended; retrieved; moved up or down; side-ways, etc. as and when required. Body 757 may be rotated from one side to the other. Attached to the boom or arm 758 is a sliding sleeve 759; which in turn holds an extendable and retrievable segmented crane boom 619. Attached to the tip of boom 619 is a tidal turbine 472ax. Such portable tidal turbine units 750 may be used to harness additional tidal energies. Portable tidal turbine units 750 may comprise of: (1) an integrated turbine-generator unit with nacelle 611; or (b) a split unit configuration. For split unit apparatus, torque transmission mechanisms 687 to a central generator may comprise: (a) shafts 691; extended shafts 692; 595ax; gear boxes 583ax; gear-wheels 693; 695; (b) line reels 582ax'; 582ax"; transmission lines 591ax system; (c) dual line reel drums 582ax cum 588ax with transmission lines 591ax protected by hard cover 592ax; (d) sprockets 738; 739 and roller chains 742 system; (e) pulleys wheels 743; 744 and belts 746 system; universal couplings 666.

FIG. 5G illustrates an integrated counter-rotational turbine-generator unit 471ax wherein multiple turbines 472ax of apparatus 750 may be directly used with a generator (nacelle 611) in generating power. The unit may be borne by mechanized hydraulic or pneumatic booms 758; and arms 619 of apparatus 750. And may be used on the outriggers 747p; 747s; at the sides of ship 741; supporting beams 652; grating 703; flooring 715; and configured to form part of system 740. The unit may be split into three portions with the fore and aft turbines 472ax configured to drive the shaft cum magnet 476ax clockwise. While the turbine 472ax located in the middle may be used to drive the wire coils 474ax anti-clockwise. Or vice versa. Internally sealed body joints 761 integrated the three portions together.

FIG. 5H and FIG. 5I illustrates an integrated hybrid surface and underwater ocean renewable energies (ORE) generation platform 760. Wherein a combined surface platform 740; or its variant 740v may be flexibly integrated with a plurality of underwater turbine-generator units 700 to form ORE system 760. The hull 737 of ship 741; or surface platform 740; may be configured with a plurality of customized underwater attachment apparatus 762. Said extendable and retractable attachments may comprise of struts; pillars; or beams 762. Wherein a plurality of underwater turbine-generator units 700 may be flexibly connected to customized struts or beams 762 by means of traction poles 705 and traction pads 706. Flexibly attached or anchored to the surface platform 740 for support; flexibly detached whenever required. Wherein, ocean tidal energies; or marine-hydro-kinetic energies may be extracted by means of the plurality of hydro-turbines units 472ax of system 700. Offshore wind energies may be extracted by means of wind-turbine units 472ax; 477ax; 477vax on the surface platform 740, or on the deck 736 of ship 741. Bagged apparatus 222ax; 76ax; HAV-100ax; HUV-200ax; HAV-400ax; HAV-400Max; etc. may also be used. Power generated by the multiple units of system 700 may be routed to mother-ship 740 for processing in rectifiers 622; transformers 622; etc. prior to transmission by underwater cable 457ax to shore based sub-stations 622. Multiple units of ship 741; outriggers 747; pontoons 734; ballast tanks 578ax; buoys 508ax may be interlinked by means of a floating platform

grid 703 and combined together to form surface platform 740; 760. And may be integrated with fixed legs 291 platforms 290; floating platforms comprising: semi-submersible platforms 292ax; flatbed platforms 293ax; inflatable floating bodies 294ax; including mother ships 289ax; factory ships 296f/ax; tankers 296t/ax; FPSO vessels 511ax; forming an ocean renewable energies extraction and conversion complex and ecosystem 300ax. Other equipment may comprise: customized submarine boats 220ax; personal submersible vehicles 220aax; UUV-230ax; UUTV-230ax; configured with robotic appendages 522ax; robotic limbs 522ax; for executing delicate and dexterous underwater tasks that would normally have been undertaken by humans. But due to hazardous conditions immediately dangerous to life and health (IDLH); such tasks may only be performed by means of robotic-drones; or drone-bots.

Optionally, as illustrated at the right side of FIG. 5I; a variant configuration may comprise the routing of tidal energies extracted by means of submerged system 700 to a surface based generator 585ax; 590ax in ship 741 for generation. Wherein tidal power extracted by means of hydro-turbine units 472ax may not be converted directly in body 701; but may be combined together by means of gearboxes 583ax and extended shafts 692 in the submerged body 701; said combined torque may be transmitted by means of a plurality of extended shafts 692' configured inside customized traction poles 705 cum beams 762 to generator units 590ax; 585ax mounted in the bellies of surface platforms 740 comprising ships 741; catamarans 747; buoys 508ax; ballast tanks 578ax; etc. Wherein, extracted tidal energies from multiple units of system 700 may be combined together to power one driven unit 585ax; 590ax aboard outrigger 747. This variant is illustrated at the right side of FIG. 5I. Such an additional torque transmission step (from 700 to 747) may entail some loss in energy during the total conversion process. However, the numerous advantages gained may far outweigh any minor loss; such as the huge costs savings related to design, engineering and production of surface based generation systems versus miniaturized underwater systems where water proofing and leak prevention of electrical components incurs extremely high costs at present. Other advantages may be related to the safety, health and security issues of locating such delicate and sensitive electrical generation systems underwater. Preferably located on surface based platforms 741; 747; 508ax; 578ax; spar buoy 607ax; pontoons 734; etc. above water. Any transmission loss suffered may be recouped by means of adding more turbine units to make up. And by extending the range of the energy farm; by increasing the area; volume; renewable energy extraction space. By venturing higher, deeper, further out. Because wind-turbines; hydro-turbines; torque transmission shafts; sea-water lubricated gear-boxes; etc. does not cost a bomb. Water proofing; leak proofing and water-tight sealing systems for individual nacelles 611 configured with one-step, direct energy conversion systems (kinetic-mechanical-electrical energies) comprising integrated turbine-generators 611—costs a bomb.

FIG. 5J to FIG. 5L illustrates a variant arrangement of FIG. 4A to FIG. 4I and FIG. 5H to FIG. 5I; wherein said variant platform 760v may be configured with an ocean surface floating platform 740v supporting an underwater deployment comprising a flotilla; an armada of floating underwater; buoyancy-neutral turbine-generators 700; suspended in the sea and ocean at various depths. Enabling extraction of tidal stream energies across the water column; spanning the bottom seabed 537ax right up to the top water surface 621 (floating platform 740v); covering hectares/or

square kilometers in area/or cubic kilometers in volume. FIG. 5J illustrates the frontal view; whereas FIG. 5K illustrates the side view of the deployment of such a submerged array of undersea apparatus 700. FIG. 5L illustrates the attachment points 763 connecting apparatus 700 to anchoring lines 295ax. Wherein, said surface platform 740v configured comprises a plurality of ships 741; catamarans 747; outriggers 747; trimarans 747; mooring buoys 508ax; ballast tanks 578ax; pontoons 734; etc. flexibly inter-connected by means of beams 652; platform gratings 703; solid structural floorings 715; etc. Said underwater power generation system comprising a flotilla; an armada of floating bodies 701 wherein, thousands upon thousands of horizontally disposed floating turbine-generator units 700; may be suspended at various depths in the deep seas and the oceans by means of mooring lines 295ax. The bottom end of said mooring lines 295ax may be securely anchored to the seabed 537ax by means of man-made: drill strings 651; concrete pads 653; piles 562ax; beams 562ax; pillars 545ax; plugs 564ax; etc. integrated into the naturally occurring seamounds 555ax and underwater ecosystem. Drill-string anchoring system 650 and 660 (FIG. 3A; FIG. 3G) may be used for anchoring of mooring lines 295ax. This enables periodic change out of lines 295ax to be done systematically.

The top end of mooring lines 295ax may be attached to line reels 52ax associated with the floating surface platform 740v. The plurality of lines 295ax may be modified; specially configured; adapted with a plurality of attachment apparatus 763; enabling anchorage of units 700 at various designated depths in the water column. Instead of two fore and aft lines as illustrated in the simplified figures; each of the fore and aft attachment points for units 700 may comprise dual lines, one at each side (total 4 lines): one line each located fore port and starboard; aft port and starboard. Or, more lines may be configured if required. Points of attachment may comprise use of traction poles 705; and customized traction pads 706 which may be flexibly attached to; and/or detached from a matching customized anchoring apparatus 763; configured at/or along specific points of lines 295ax. Such attachment mechanisms may comprise of: magnetic; vacuum-suction effects; mechanical clamping systems; etc. or a combination apparatus 763 configured from said variety of individual components. Said surface platform 740v may be mounted with wind turbines 472ax; 477ax; 477vax; on deck 736 or on turntable 745; and centralized generation units 585ax; 590ax in the bellies; or inside sheltered housing structures on deck. Floatation apparatus 765 may be used to shore up buoyancy of lines 295ax and apparatus 700 at various depths. Apparatus 765 may comprise a variant hydro-dynamically shaped ballast tank or vessel 690 armed with automated ballast-buoyancy control system 686 (minus the turbine 471ax) of FIG. 3K to FIG. 3L. Underwater power transmission line 457ax running from anchor point 764 on the seabed 537ax to the surface platform 741 may be configured with teed-off connections 766 enabling transmission of power generated by individual units of turbine-generator 700. Work-horse units comprising: UUVs-230ax; UUTVs-230ax; PSVs-220ax; submersible-boats 220ax; may be deployed for monitoring; minor repairs; and their main tasks of shunting (pilotage) units 700 to and from their specific berths (attachment points 763) on lines 295ax. Such as the removal of a unit 700 for repair; then reinstate back for normal operation. A system 760v configured for operably generating multi-Giga-Watts of clean and green; blue ocean renewable energies (ORE) for human consumption.

FIG. 6A to FIG. 6E illustrates a split unit tidal energy extraction system 770 wherein, a multitude of floating apparatus 768 comprising hydro or tidal turbines 472ax (drive units) supported by means of self-buoyant floats 767 mounted on an extended shaft 595ax; 692ax; (transmission units) connected in between twin structural bodies 607ax; 771; may be configured for use with vertically disposed generators 585ax; 590ax; (driven units) configured inside the structures 607ax; and 771. Structure 771 may comprise of a customized, reinforced concrete structure specially configured for extraction of ocean renewable energies—tidal stream and offshore wind energies. Structure 607ax may comprise of a floating Spar unit moored to the seabed 537ax by means of anchoring lines 295ax. Multiple units of such horizontally configured shafts 595ax; 692 may be affixed between said structures 607ax and 771 at intervals; arising vertically from the seabed 537ax to the surface 621 of the sea; from the bottom 537ax to the top 621 of the water column. Wherein, a plurality, a multitude of such structures 607ax and 771 may be configured running parallel to each other in the sea and ocean based energy conversion farm 300ax. Said structures may be flexibly configured wherein, one structure 607ax may be paired with another similar structure 607ax; or structure 771 may be configured with another structure 771. Or with a plurality of other customized floating; submerged; submersible seaborne structures; fixed legs 291ax jackets 290ax; floating flatbed platforms 292ax; 293ax; 294ax; etc. in farm 300ax. Said floating body 607ax at one end may comprise of a Spar structure anchored to the seabed 537ax by means of mooring lines 295ax; whereas body 771 with walls 772 at the other end may comprise of a permanent structure affixed to the seabed 537ax. Inside of both structures 607ax and 771 may be configured a tall and long vertically disposed generator 585ax; 590ax; running from the top to the bottom (sea surface 621 to seabed 537ax). Such that the plurality of floating tidal turbines 768 mounted on extended shafts 692 may be used to extract the kinetic energies of tidal streams; converting said kinetic energy into mechanical energy; transmission of torque generated by means of extended shafts 692 to gearboxes 583ax'; 585ax"; then into dual units of generators 585ax'; 590ax'; 585ax"; 590ax" kept inside structures 607ax and 771; located fore and aft; upstream and downstream of the tidal current flow. The distance in between structural bodies 607ax and 771 may be: 100 meters; 1 km; 5 km; 10 km; 20 km; 50 km; etc.

Disclosed herein is a structural configuration and arrangement wherein: a (one) singular extended shaft 595ax; 692; carrying a multitude of tidal turbine units 768; may be configured with both ends (fore and aft edges of horizontally disposed shaft 692) connected to; driving, propelling and powering two (twin) units of counter-rotating generators; one at each end; at the same time (at one point in time). Wherein, one said generator 585ax' (fore) resides in structure 771; one said generator 585ax" (aft) resides in the Spar structure 607ax. Said renewable tidal energies conversion process comprises: kinetic energy (tidal current) to mechanical energy (tidal turbine 768; extended shaft 692) to electrical energy (generators 585ax'; 585ax").

FIG. 6B illustrates one single floating tidal energy extraction unit 768; comprising of: a turbine 472ax (no nacelle) hemmed in by dual floating bodies 767f (fore); 767a (aft); borne by a fixed rotating shaft 595ax; 692; in the middle. Dual floatation bodies 767f; 767a; filled with air 683; positioned fore and aft of turbine unit 472ax is configured to support the weight of turbine unit 472ax with its buoyancy. Such that the combined apparatus may be configured to be

self-supporting; buoyancy neutral; weightless; able to keep afloat; and remains suspended in the water. Fitted with vertical and horizontal fins 206ax; 207ax; floats 767 enables directional orientation relative to tidal current flow; keeping the turbine unit 472ax in optimal position. The stabilizers 206ax; 207ax; channels a streamlined flow of tidal current to the blades of turbine units 472ax. Optionally, floats 767 located fore and aft of turbine 472ax may be configured without any fins or vanes 206ax; 207ax. They may be affixed onto extended shaft 692; rotating together with shaft 692. Floating bodies 765 may also be used for supporting system 770. The hubs of turbine 472ax may be affixed to customized, specially configured traction pads 769 on the extended shaft 595ax; 692; spaced at regular intervals. A plurality of turbines may be attached to said shaft 692 stretching between the two structures 607ax; and 771. Said plurality of floats 767 may in turn be kept in position along the extended shaft by means of twin coupling 774 installed fore and aft; at both ends of the apparatus 767. Tidal turbine unit 768 may be configured for bi-directional operability; wherein, tidal current flowing in both directions due to flow and ebb (to and fro) may be used to drive the unit. Except for a change in the direction of tidal flow and turbine rotation; all parameters remains the same.

FIG. 6C illustrates a piece of coupling 774 which may be configured from two components 774i; 774e. The inner coupling 774i may be securely locked onto the extended shaft 595ax; 692; staying in position; following the rotating movement of extended shaft 595ax; 692; which transmitted the torque. Inner coupling 774i may be configured to turn freely and independently of external coupling 774e; by means of ball bearings 752 placed in between the twin couplings. Whereas, the external coupling 774e affixed to floats 767 kept the whole apparatus in position; without being affected by the movements of the turbine blades 472ax; and the torque transmitted by extended shaft 595ax; 692.

FIG. 6D illustrates a float body 767 which may be configured with a plurality of fixed control surfaces; two vertically positioned fins 206ax; two horizontally positioned fins 207ax. With the topmost portion of the vertical fin 206 configured with a buoyant tube 773 filled with air 683; keeping apparatus 767 in an upright position. Thus the whole extended shaft 692; turbine rotor blades 472ax; fore and aft internal coupling 774i may be configured to move freely. Turning independently of the dual supporting floats 767f; 767a; and the external couplings 774e mounted fore and aft.

FIG. 6E illustrates a customized drive unit comprising twin turbine blades 472ax with a flexibly configured shaft sleeve 775; a swing-gate section 775s; and an internal sliding sleeve portion 776. Such a configuration enables flexibility of removing a pair of defective turbine blades for repair; and instantly reinstalling a replacement set of turbine blades onto the extended shaft 692. Wherein, turbine 472ax may be moved into position on the extended shaft 692 by means of surface hoists or cranes; UUTVs-230ax; PSV-230ax; etc. Shaft sleeve 775 with both the swing-gate section 775s; and the sliding sleeve 776 primed open; may be slotted into position on the customized traction pad 769 of extended shaft 692. The inner sliding sleeve 776 (refer to arrow) may be closed into position; and the swing-gate section 775s clamped shut and locked. Shaft sleeve 775 of turbine 472ax is now securely fastened onto extended shaft 692.

Instead of the split-unit configuration as disclosed in FIG. 6A to FIG. 6E above; system 770 may optionally be con-

figured with a plurality of integrated one-step direct conversion tidal turbine units 471ax (with nacelles 611); supported by enlarged floats 767; 765; a variant self-regulated ballast vessel 578ax (system 690 as disclosed in FIG. 3K to FIG. 3L). Instead of structures 771 and 607ax; a plurality of supporting pillars 708 may be used. Instead of extended shafts 692; the plurality of floating turbine units 471ax may be secured by anchoring lines 295ax to pillars 708. With undersea cables 457ax; teed-off connections 766 used for power transmission as in FIG. 5J to FIG. 5L.

FIG. 6F illustrates an improved variant configuration of centralized split unit counter-rotational generator 585ax; 590ax which may be used in structure 771; 607ax. Wherein said vertically configured generation system may be modified into sections 777; 777'; 777"; with torque transmission gears 583ax or gearboxes 583ax installed at each end (fore and aft; top and bottom) of said generation section. Section 777 may be connected to the bottom section 777'; and the top section 777"; by means of central shaft 581ax. Each section 777 may be configured measuring: 10 meters; 30 m; 50 m; etc. Segmentation enables effective transmission of mechanical torque into the counter-rotational generation system in order for it to work efficiently. Central shaft 581ax mounted with magnets 476ax may be configured to be driven by means of gear-wheels 695; 696. A plurality of shafts; gears and gearbox transmitted the mechanical torque from the drive units to the central shaft 581ax by means of: extended shaft 692; gearbox 583ax; gear 696; gear-wheel 695. Gear-wheels 695 are directly mounted on and connected to central shaft 581ax. Gear-wheel 695 does not have any contact with top yoke 484' and bottom yoke 484". Likewise the peripheral wire-coils 474ax surrounding the magnets 476ax of section 777 may be configured to be driven by means of gear-wheels 694; 693. A plurality of shafts; gears and gearbox transmitted the mechanical torque from the drive units to the top yoke 484ax'; and the bottom yoke 484ax" by means of: extended shaft 692; gearbox 583ax; gear 694; gear-wheel 693. Gear-wheels 693 are directly mounted on and connected to the top yoke 484ax'; and bottom yoke 484ax". Gear-wheels 693 does not have any contact with central shaft 581ax.

Central shaft 581ax mounted with magnets 476ax may be configured to run continuously from one section 777 to adjacent interconnected sections 777'; 777"; etc. Optionally, central shaft 581ax in between generation sections 777'; 777"; 777""; may be connected by means of clutch-gear mechanism 587ax. Such variability and flexibility of configuration ensures optimal performance of said generation system. Wherein, any defect in generation (driven) section 777 (for example: due to any defects arising from the plurality of associated distributed units of drive apparatus) may be decoupled and isolated from other sections of the centralized generation system 585ax; 590ax. Until said defective components had been rectified; section 777 powered up; its performance validated; may the section be recoupled back to said centralized generation system by means of mechanism 587ax.

FIG. 6G illustrates an optional configuration wherein generating elements may be configured to be located above the water surface 621. Wherein said torque transmitted by means of horizontally extended shafts 692; may be further transmitted by means of gearbox and additional vertically extended shafts 692' mounted inside the structures 771 (or 607ax) to generators 585ax; 590ax located at the apex, at the top of structures 771. Above the water surface 621.

FIG. 6H illustrates a structural configuration wherein an extended tidal energy farm 300ax may comprise of a linear

arrangement in which, a series of multiple structures 771 (and/or, 607ax) may be configured in series. With extended shafts 692 connected in between each pair of structures 771 (or 607ax); one upstream structure 771 linked to another downstream structure 771'. Wherein said downstream structure 771' (now referred to as an upstream structure 771') may in turn be linked to another structure 771" configured further downstream. And so on. Each pair of said structures 771 interconnected by means of a plurality of extended shafts 692 bearing a multitude of floating tidal turbines 768. Wherein, each downstream structures may be configured with a pair of generators 585ax; one for upstream shaft 692'; another for downstream shaft 692". Such a system may be used in the river; coastal areas; deep sea or ocean.

FIG. 6G and FIG. 6H illustrates system 770; a structural configuration wherein a multitude of fixed and enclosed marine structures 771 resting on sea-legs 772 affixed in seabed 537ax may be constructed, spaced at intervals forming an ocean energies extraction plant 770. FIG. 6G illustrates a perspective side-sectional view of an enclosed marine structure comprising top-side housing structure 771; and submerged sea-legs 772 for harnessing ocean energies. Providing an optional configuration of FIG. 6A wherein, said generating elements maybe located above the water surface 621. Wherein said torque transmitted by means of horizontally extended shafts 692 mounted with a multitude of tidal turbines 768; may be further transmitted by means of a plurality of gearboxes 583ax and additional vertically extended shafts 692' mounted inside the submerged structure 772 to generators 585ax; 590ax; 777 located at the apex, atop structure 771 (or Spars structure 607ax; ocean pods 785); well above the water surface 621. Torque generated by wind turbine 472ax maybe transmitted to generator 777 for conversion to electricity.

FIG. 6H illustrates an optional configuration of FIG. 6A; showing a plan view of an integrated structural configuration wherein multiple interconnected marine structures 771 may be arranged to maximize harvesting of ocean renewable energies comprising: solar; wind; tidal; wave energies; OTEC; salinity gradient energy converters; etc. Wherein an extended tidal energy farm 300ax may comprise of a linear arrangement in which, a series of multiple structures 771 (and/or, Spars 607ax) may be configured in series. With extended shafts 692 connected in between each pair of structures 771 (or 607ax); one upstream structure 771 (for example: marked A1) linked to another downstream structure 771' (for example: marked A2). Wherein said downstream structure 771' (marked A2) may now referred to as an upstream structure 771'; said structure 771' (marked A2) may in turn be linked to another structure 771" (marked A3) configured further downstream. And so on. Said structure 771 may also comprise of a floating Spars structure 607ax; an ocean Pods structure 785. Each pair of said structures 771 may be interconnected by means of a plurality of extended shafts 692ax bearing a multitude of floating tidal turbines 768. Wherein, each downstream structures may be configured with a pair of generators 585ax; 590ax; 777; one for upstream shaft 692'; another for downstream shaft 692". Such a system may be used in the river; coastal areas; deep sea or ocean. Shape of said hydro-dynamic structure: 771; 607ax; 785 may be varied, creating minimal resistance or obstruction to tidal flow.

Preferably, such permanent marine structures 771 located upstream may comprise: fixed concrete and steel structures securely built into the seabed 537ax. Whereas the floating structures further downstream may comprise Spars 607ax or ocean Pods 785; said apparatus held in position by means of

cables anchored to the seabed 537ax; wherein their positions may be shifted slightly to follow the tidal flow. Or, intentionally shifted to be aligned at an angular inclination to the tidal current flow; in order to maximize engagement of said energy conversion apparatus with fresh tidal flow. A multitude of inter-connected tidal turbines 768 mounted in between the Spar structures 607ax may be used to transform tidal stream into mechanical energies. The turning moment (torque) generated may be transmitted by means of elongated shafts 692ax; and used to power vertically disposed generators 777 (FIG. 6A) located inside the vertically disposed hollow cavities 778 of the "legs" 772 of fixed structures 771; floating Spar structures 607ax; floating ocean Pods 785. In the case of Spars structures 607ax and ocean Pods 785; the bottom portion of the pillar like floating protrusion (similar to sea-legs 772) may preferably be filled up with water for structural stability and balance. Such that portions of said pillar not used for the purpose of torque transmission may be filled up with sea water. Torque may also be channeled by means of extended, vertically disposed shafts 692 located inside energy transmission wells 778 formed by sea-legs 772 of structure 771; to horizontally disposed generators 777 located on the surface. Inside the top portion of Spar structures 607ax; where such surface based generators; transformers 622; and other delicate electrical switching gears and equipment 622 are kept dry, secure and well protected from the external environment. FIG. 6I and FIG. 6J shows a flexibly extendable and retractable strut 779; or shunt 779 which may be used to connect portions of elongated shafts 692'; 692" together. Accommodating and allowing for minor shifts in the position and length of the shaft portions 692' and 692". FIG. 6I illustrates the side-view cum cross-sectional view. FIG. 6J illustrates the plain view of FIG. 6I. The shunt 779 may be inserted into the hollow portion of modified shaft 692; connecting both portions 692' and 692" together. Shunt 779 maybe configured with a rivet shaped pin head 781 with a broad cap at both ends. Shaft portions 692' and 692" maybe configured with two long slots 782 for pins 781 to slide along; move inside said slots 782. Shunt 779 may be configured with two springs 783 at each end. Wherein, said spring 783 loaded shunt 779 may be kept in a balanced position in the middle of said twin shafts 692' and 692".

Fixed structure 771; Spar structures 607ax; or ocean pods 785 affixed into the seabed 537ax with cables 295ax may be interlinked and inter-connected to each other by means of a network of structural framework comprising: gratings 703; supporting grid of steel structures 290ax; concrete and steel bridges 784 and tube-connectors 786; girders 787; made of metal; ceramics; plastics; composite materials; etc. Such inter-connectivity strengthens the entire structural configuration of the renewable energies extraction plant 770; and provides an ocean-based platform and eco-system 300ax upon which to erect solar panels 579ax; wind turbines 472ax; 477ax; bagged wind and water generation systems 100ax; 200ax; wave energy converters; ocean-thermal-energy-converters (OTEC); drones system 60ax; 80ax; 90ax; integrated with turbines 500ax; 500vax; to form wind and tidal energy generators: 800; HAV-800; HUV-800; turbine-generators 800. Forming a truly integrated ocean renewable energies (ORE) generation plant 300ax/or ORE farm 300ax; specially configured for extraction of ORE comprising: tidal; waves; wind; solar energies; etc.

FIG. 6K illustrates a variant sea-based structure 780a; a plurality of wind and tidal energies conversion apparatus mounted on monopile 788 affixed to the seabed 537ax. This may be used in shallow waters. Dual wind turbines 472ax

and tidal turbines **472ax** generated torque may be transmitted by means of: gearbox **583ax**; extended shafts **692** mounted inside rotational energy (torque) transmission well **778**; and combined together at the surface based platform **736** to power a generation module **585ax**; **590ax**; **777**.

FIG. 6L illustrates a variant sea-based structure **780b** of FIG. 1D for use in deeper waters. Multiple tidal turbines **472ax** and wind turbine **477ax** maybe mounted on a larger and taller monopile **788**. Torque generated by said multitude of wind and tidal energies conversion apparatus may be transmitted by means of gearbox(es) **583ax**; extended shafts **692**; and used to power a surface based generation module **585ax**; **590ax**; **777**.

FIG. 6M illustrates a variant configuration **780c** comprising a multitude of vertical-axis wind and tidal turbines **477ax** configured in proximity to each other. Operating independently of each other, their individually generated torque may be transmitted by means of extended shafts **692**; gearboxes **583ax**; channeled and combined together in powering a centralized generation module **585ax**; **590ax**; **777**. Said generator safely located on the surface platform **736**: above sea-water **621ax** level and tidal turbine **477ax**; and below, at the bottom of wind turbines **477ax**. Wherein, wind energies and tidal energies extracted by means of said plurality of energy conversion apparatus may be used to power one centralized generator **777**. Of course, torque generated by individual turbines may also be configured to power integrated turbine-generation modules; nacelles **611**; **471ax**; as is the standard practice.

However, such water-proofing design for submerged generators (tidal turbines); or miniaturized generators (high up in the nacelles of wind turbines) may be much more expensive; delicate; less durable; more difficult to maintain than standard surface based generation systems used the world over. Those systems **585ax**; **590ax**; **777** built on dry land; or (above water) surface; located on floating platforms; in barges; ships; etc. may be constructed of heavy-duty, rugged design; easy to access for checking; maintenance and repair of the machineries. Without the need to bring them down/or up from a great height (wind turbines); nor the need to lift them down/or up from the seabed **537ax** (tidal turbines) using tall/or large cranes. Of course some losses in efficiency may occurs due to frictional loss and transmission loss (shafts **692**; gear-boxes **583ax**) in between the energy conversion components: the turbines (kinetic to mechanical) and generators (mechanical to electrical). This slight loss might well be off-set by adding extra turbines to make up for the desired production. Electrical energies produced by means of said plurality of wind and tidal energies conversion devices; apparatus; including generators **585ax**; **590ax**; **777**; of present invention, may be transmitted from generation modules **777** by means of underwater cables **457ax**; down through monopile **788** casing; legs **291ax** of platforms **290ax**; etc. to the seabed **537ax**. Said cables **457ax** maybe connected to the main submarine transmission header cable **457ax**" by means of connectors (alike teed connector **766**). Where it may be further routed by means of said cables **457ax**" laid in submarine cable-trenches **789**; to shore based electrical transformers; sub-stations; electrical power rectification-distribution facilities **622**; etc.

FIG. 7A illustrates a variant system **780d** of FIG. 6A to FIG. 6M wherein, torque generated by means of wind turbines **472ax**; **477ax**; and floating tidal turbines **768** (**472ax**); **477ax**; may be combined together powering a surface, deck **736** and platform **290ax** based centralized generation plant **777**; **585ax**; **590ax**. Wind turbines **472ax**; **477ax**; may be mounted atop fixed legs **291ax** platform

**290ax**. Vertical axis wind turbine **477ax**; and horizontal axis wind turbine **472ax** mounted on pillars **469ax**; transmitted their torque from the central shaft **475ax**; to generator **777** by means of extended shafts **692** and gearboxes **583ax**.

Said floating turbines **768**; **471ax** may be configured differently from each other. In one configuration torque generated by a plurality of submarine floating turbines **768** may be transmitted by means of gearboxes **583ax** and extended shafts **692** to deck **736** mounted generator **777**. Said floating tidal turbines **768** configured with neutral buoyancy mounted on extended shaft **692** may be anchored at the bottom end to bearing box **586ax**; which may be mounted on concrete base **653** secured to the seabed **537ax** by means of drill strings **651**; piles **562ax**. The top end of extended shaft **692** may be connected to gearbox **583ax** and generator **777** on platform **290ax**. Floating tidal turbines **768** of neutral buoyancy (weightless when suspended in the sea water) impose zero forces of stress or strain by the apparatus themselves. All such forces created would be due to their engagement with tidal currents; and the transformation; conversion of energies; from kinetic to mechanical to electrical energies.

In a variant configuration, renewable electricity **456ax** generated by means of tidal energy conversion unit **471ax** comprising: tidal turbines **472ax** integrated with nacelles **473ax** (containing coil **474ax**; magnet **476ax**; also refer to apparatus **611**); may be transmitted by means of undersea cables **457ax**' to transformers in substation **622** for rectification. Teed-off connectors **766** may be used to transmit power off-take between individual tidal energy conversion unit **471ax** and common transmission cable **457ax**'. Rectified high-voltage power from substation **622** may be transmitted by means of undersea cables **457ax**" (larger capacity than cables **457ax**') to shore based electrical sub-stations cum transmission systems. Transmission lines **457ax**" may be routed through the legs **291ax** of fixed platform **290ax**; and undersea transmission cable trenches **789**. Buoyant tidal turbines **471ax** integrated with nacelles may be configured with larger floats **767** to cater for the heavier nacelles **473ax**. Tidal turbine-generators **471ax** (**611**) may be held in place by means of securing lines **295ax**. The buoyancy of lines **295ax** may be augmented by means of individual floatation apparatus **765**.

The bottom end of lines **295ax** may be anchored at point **764** to concrete base **653** secured by drill strings **651**; drill casings **651**; sea piles **562ax** to the seabed **537ax**. The top end of line **295ax** may be connected to integrated winches **59ax** cum line reels **52ax**; mounted on the lower deck **736** of platform **290ax**. Optionally, said winching system **59ax** may also be configured to comprise of double lines system. (Refer to U.S. patent Ser. No. 10/113,534 FIG. 6O; system 510u.) Anchoring lines **259ax** may be substituted by lines **542ax**. Wherein, said double lines **542ax** may form a closed loop. Top end anchored by winch **59ax**; the bottom end held by a pulley **48ax** mechanism at point **764**. Wherein, said floating turbine-generators **471ax** may be shifted upwards; or downwards by means of lines **542p'**; **542p''**; and **542s'**; **542s''**; for the purpose of periodic inspection, maintenance checks and/or repair to damages.

In a variant form, horizontal axis turbines **472ax** may be configured with its blades disposed at an angular inclination. The top portion **791** of pillar **469ax** maybe tilted or slanted backwards. Inclined portion **791** may be connected to main pillar **469ax** by means of a joining collar **792** allowing rotational movement. Such a configuration shifts the center of gravity **793** of the gearbox **583ax** plus heavy turbine blades **472ax** backwards; from front to center, nearer to the

central shaft **595ax** (**691**) in the middle of pillar **469ax**. The turbine on the left hand side of the diagram maybe more optimally positioned than the turbine on the right hand side. As its center of gravity **793** coincides with the shaft **595ax** (**691**) mounted in the center of pillar **469ax**; rather than falling outside of pillar **469ax**. Which produces undesirable structural stress and strain on pillar **469ax**.

FIGS. **7B** and **7C** illustrates a variant system **790a** of FIG. **6A** to FIG. **6C**. FIG. **7B** illustrates the side view. FIG. **7C** illustrates the plan view; wherein, structures comprising sea dykes **790**; sea fences **790**; and/or sea water channeling walls **790** may be used for diversion; convergence; concentration of tidal flow; enhanced augmentation of tidal velocities for driving tidal turbines in shallow coastal waters. Two supporting structures **795** comprising: an upstream structure **795'**; and a downstream structure **795''** may be constructed; aligned with the tidal current flow channeled by sea fences **790**. Said supporting structures **795** erected may comprise a plurality of vertical beams (legs) **708** and horizontal beams **715**. On top of horizontal beams **715** may be erected the deck flooring **736**; gratings **703**; etc. Upon which may be placed generation module **777**; substation **622**; wind turbines **472ax**; etc. Multiple tidal turbines **768**; **472ax** (without nacelles) may be configured on a single extended shaft **692** connected between said upstream and downstream structures. The upstream and downstream gearbox units **583ax'**; **583ax''**; may be supported by auxiliary beams **794**. Wherein, torque produced by said tidal energy conversion units **768**; **472ax**; may be transmitted by means of said gearbox units **583ax**; from horizontal shaft **692**; to vertical shaft **692'**; and in turn, to deck **736** mounted generators **777'**; **777''**; where it maybe transformed into renewable electricity. Likewise, torque produced from wind energies by means of energies conversion units **472ax** maybe transmitted from the top of the pillars **469ax**; by means of transmission apparatus **595ax**; **583ax**; down to surface or platform **736** mounted generators **777'** and **777''** for conversion into electricity. Other components of torque transmission system **687** (FIG. **5C**; FIG. **5D**) may also be used. Generation modules **777** may be aligned vertically or horizontally (FIG. **7C**) to suit the renewable energy extraction plant requirements.

FIG. **7D** and FIG. **7E** illustrates a variant system **790b** of FIG. **7B** and FIG. **7C** wherein said structural beams **708**; **715** may be configured as a long extended platform; a supporting structure for mounting shrouded; or hooded tidal energy conversion apparatus comprising: penstocks **575ax**; turbines **472ax**; turbines **477ax**; turbine-generators **500aax**; **500vax**. FIG. **7D** illustrates the front view. At the left side is illustrated a water-bags **40ax** secured to the framework formed by vertical beams **708** and horizontal beams **715** by means of lines **633**. Other means of attachment may also be used. Tidal stream flow may be engaged by said bags **40ax**; constricted from a large square-shaped inlet port **25ax** through smaller outlet port **809** integrated with penstock **575ax**. The right side of FIG. **7D** illustrates a free flowing open tidal turbines **472ax** (without shroud) which may also be used for conversion of tidal energies. Torque produced by said turbine **472ax** may be transmitted by means of gearbox **583ax**; and shaft **691** inside external housing **592ax** to generator module **777** located on the surface or top deck **736**. Turbine **472ax** may also be configured with generators integrated into the nacelles of turbines, forming an integrated turbine-generator unit **471ax** (more expensive). Kinetic energies harnessed by said plurality of (wind; tidal) energy conversion apparatus (mechanical energies) maybe transmitted by means of torque transmission system **687**

(cheaper, but with some frictional losses); to split unit, surface mounted generators **777** (electrical energies).

FIG. **7E** illustrates the plan view of the left side of FIG. **7D** wherein, said fabric water bag **40ax** maybe secured to vertical pillars **708**; and horizontal pillars **715**; by means of lines **633**. A penstock **575ax**; a tidal turbine **472ax** (torque); or turbine-generator unit **471ax**; **617**; may be mounted in the center. FIG. **7E** is shown as a sectional; see-through view of the surface flooring **736**; without the top deck **736** (assumed to be transparent). Mechanical energy derived from conversion of kinetic energy (moving fluid) may be directly recon-verted into electrical energy by means of a generator mounted in the nacelle (**471ax**; **617**). Said mechanical energy created may also be transmitted by means of elongated shafts **692** and gearbox(s) **583ax** to surface mounted generator **777**; located on deck **736** of platform. Top surface **736** may be configured as an access way; mounted with: generators **777**; sub-stations **622**, transformers **622**; solar panels **579ax**; wind turbines **472ax**; **477ax**; etc. The fabric shroud may be securely tied to the sides of framework **708**; **715** by means of lines **633**; clamps, etc. Fabric shrouds **40ax** may also be configured from; or comprise of other materials such as: semi-solid pliable plastics; solid state plastics; composites; metal; wood; etc. Said shroud **40ax** may also be supported by a framework structure **232ax**; **619** (refer FIG. **1C**; FIG. **1D**) made of like materials for keeping its physical functionalities in order for the system to work efficiently. In entrapping; channeling; diverting; and constricting said flow of fluid into said energy conversion apparatus comprising: penstocks **575ax**; turbines **472ax**; **477ax**; **471ax**; **617**; **500aax**; **500vax**; etc. For practical purposes said apparatus may, preferably be configured for bi-directional (bi-di) use. Wherein, said tidal current may move forward during incoming tide; then reversing direction during the outgoing tide. Such that said apparatus may be configured to work well with either the tidal ebb or the tidal flow.

FIG. **7F** illustrates a wind turbine and tidal turbine mounted on a floating Spars structure **607ax** connected to a common surface based generator **777**. Said torque may be combined for powering said generator **777**. Torque from the wind turbine **472ax** may be configured to drive the rotor magnets **476ax**; while torque from the tidal turbine **472ax** may be configured to drive the rotor wire-coils **474ax**. Or the other way round. Said floating Spars structure **607ax** maybe anchored to the seabed **537ax** by means of securing lines **295ax**. An integrated ocean energies harvesting; conversion apparatus. Torque from the wind turbine **472ax** maybe transmitted from the top of pillar structure **469ax** by means of gearbox **583ax** and extended shaft **595ax**; to the generator **777** mounted below, at its base; inside structure **607ax**. While torque from the tidal turbine **472ax** maybe transmitted from the bottom of the legs structure up to surface mounted generator **777** by means of extended shafts **692ax** and gearbox **583ax**.

FIG. **7G** and FIG. **7H** illustrates system **790c**. Wherein a dyke-wall structure **790** incorporating tunnels **799** integrated with a plurality of tidal turbines **472ax** may be used to entrap and harness ocean tidal energies. FIG. **7G** illustrates a perspective view; while FIG. **7H** illustrates a sectional side view of FIG. **7G**. Wherein, torque generated by said tidal turbines may be transmitted to surface **736** based generator **777** by means of shaft **691**; elongated transmission shaft **692**; and gearbox **583ax**. Tunnels **799** may be specially configured in the form of square shaped tunnels **799**; or rectangular shaped tunnels **799**; for use with vertical shaft tidal turbines **477ax**. Wherein, the blades of said turbines **477ax** may be configured with flip-able hinges such that the

blades may be extended during engagement with tidal flow. Said blades may be feathered when not in active use; that is, when they are disengaged from the tidal flow). Torque derived from energy conversion apparatus comprising: vertical-axis wind turbines **477ax**; horizontal axis wind turbines **472ax**; HAV-**100ax**; HUV-**200ax** powered systems; systems **800**; etc. may be transmitted by means of torque transmission system **687**; and combined together to drive a split unit generator **777**. Mounted on top surface **736** of dyke **790**, generator **777** and related electrical equipment may be housed safely and securely in structures **622**; kept dry and protected from rain or corrosive sea water. They may be constructed of cheap; readily available materials; bulky and heavy duty components. And thus ease of installation; checking; servicing and maintenance. Zero need for expensive miniaturization of the generation system (if generator had been integrated in nacelles **473ax** with turbines **471ax** atop pillars **469ax**). Zero need for expensive water-proofing (if generator had been integrated in nacelles **473ax** with submerged tidal turbines **471ax**). Differential water level between **621-L1** (a tidal lagoon **798**) and **621-L2** (open sea/or ocean); created by the dyke-walls **790**; or a coastal sea-fence **790**; causes the flow of sea water from a higher level to a lower level. Example shown: sea water moving from **L1** to **L2** during low tide. Or vice-versa from **L2** to **L1** during high tide. Powering the tidal turbines creating renewable electricity. Wherein, torque generated from multiple sources; from a multitude of tidal and wind energies conversion apparatus; and energy extraction devices comprising: tidal turbines **472ax**; **477ax**; wind turbines **472ax**; **477ax**; windbags **100ax**; water-bags **200ax**; system **800**; in proximity/or vicinity (cluster) may be configured for transmission by means of extended shafts and gearboxes **583ax**; into a centralized generator **777**. Said generator **777** being specially configured to assimilate and accommodate said varied and diverse sources; velocities; intensities; quantities; power; of rotational energies comprising torque. And transformed into renewable electricity.

For the following figures: FIG. **8A** to FIG. **9E**, reference may herein be made to drone disclosures in parent patents: U.S. Pat. No. 8,963,362; U.S. patent Ser. No. 10/113,534; drones **60ax**; drones **80ax**; drones **90ax**; including motorized propulsion system **70ax**; **408ax**. In particular: drone **90cax** and propulsion means **70ax** of FIG. **9B**; drone **80ax** of FIG. **5A** to FIG. **5D**; FIG. **6A** to FIG. **6I**. Including FIG. **7A** to FIG. **7F**; FIG. **8A**; FIG. **9A** to FIG. **9D**; FIG. **10A** to FIG. **10C** as disclosed in U.S. Pat. No. 8,963,362. Turbine-generators **500aax**; **500bax**; **500cax**; **500dax**; etc. (FIG. **5A** to FIG. **5M**) as disclosed in U.S. patent Ser. No. 10/113,534; may be suitably configured; integrated with said drones **60ax**; **80ax**; **90ax**; propulsion system **70ax**; and utilized in wind and tidal energies extraction and conversion systems of present specification. Integrated with high altitude flying drones, UAVs, HAVs, etc. for conversion of wind energies. Used with deep-sea diving drones, UUVs, HUVs, etc. for extraction of tidal energies.

FIG. **8A** illustrates a plan view of a high altitude self-propelled flying drone HAV-**800a** integrated with a wind powered turbine generator **500aax**; mounted in the middle of the drone's long wing-span. FIG. **8B** illustrates the perspective side view and inclined body position of HAV-**800a** in operational deployment. Two main motorized propulsion turbines **70ax**; or electric-motor driven turbo-fans **70ax** may be mounted; one on each side, port and starboard near to the wing tips. Two thrusters, smaller auxiliary electric propulsion turbines **70ax** may be mounted fore and aft of the drone's flattened body **77ax**; **90cax**; assisting the wings

mounted main propulsion turbines **70ax**. Flight control surfaces **69ax**; **404ax**; **406ax**; may be used for control of said drone. Turbines **70ax** may be configured mainly for the purpose of vertical take-off and landing (VTOL). Rather than being configured for horizontal movement. Whereas, upon reaching cruising height, said drone's body may be optimally aligned in an inclined position, in such a way that its belly **801** faces the full force of the wind current. Wherein said turbine generator **500aax** unit may be able to maximize its efficiency and productivity. Said drone body's orientation and adjustment of drone's wings; its angle of attack relative to the wind; relative lengths and angle of the plurality of bridle lines **21ax**; tether line **50ax**; etc. may be made to generate aerial lift. To achieve neutral lift, wherein, the weight of the entire apparatus HAV-**800a** may be self-supported by aerial lift created by means of the wings and the flight control surfaces **69ax**; **404ax**; **405ax**; **406ax**. Such a configuration enables apparatus **800a** to stay in a relatively stable location for extended periods of time. Fore and aft auxiliary turbines **70ax** may be kept on active standby, responding whenever necessary to provide extra lift or maneuver said drone's position. Main turbines **70ax** located port and starboard may be switched on/or off automatically by means of central computerized AI controls. When the drone **800a** is airborne and in generation mode; and the main turbines **70ax** are not used for propulsion purposes. Said main turbines **70ax** may optionally; be used to engage wind current for generating power; just like apparatus **500aax**. Alike apparatus **100ax**; **200ax**; **400ax**; etc. a plurality of bridle lines **21ax**; connects the body of said apparatus **800a** at points **803**; **804**; **805** to tether line **50ax** at point **31ax**. Said tether line **50ax**; or mooring line **46ax** may in turn connect said drone **800a** to a winched **49ax** line reel drum **52ax** securely anchored to the ground.

FIG. **8B** illustrates the perspective-side view and inclined body position of HAV-**800a** relative to the flow of wind current **10ax**; water current **20ax**. Enabling the entire apparatus to be kept airborne by means of: the actions of the oncoming wind current against the reaction of its tethered body; and the interactive aerodynamic relationship between the wind current (lift) versus the tethered **50ax** body of HAV-**800a** (drag); much alike the way a kite or an airplane works. Neutral buoyancy is required for the apparatus to stay airborne by means of aerial lifting forces. Adjustments that maybe made comprises: (a) active motorized propulsion systems: turbines **70ax**; engines **408ax**; side-thrusters **70ax**; (b) flight control surfaces: wings **69ax**; **404ax**; **405ax**; **406ax**. (c) angle of attack of the wings leading edge relative to the wind direction; this may be enabled by means of internally (body **77ax**) mounted winches **59ax** controlling the length of bridle lines **803**; **804**; **805**. Wind current **10ax** flows (enters) through turbine-generator **500aax** via the belly **801** of HAV-**800a**; exiting through said drone and turbine-generator's topside **802**. Other turbine-generators **500bax**; **500cax**; **500dax**; etc. as disclosed in U.S. patent Ser. No. 10/113,534 may also be integrated into and used with drone HAV-**800**, forming a family of "High Altitude Flying Energy Generators."

All airborne and seaborne apparatus of present invention may be configured with UAS; UUS capabilities such as: automated GPS guidance; capability to determine the position of an individual apparatus by like passive means; or active means; means of automated self-adjustment and self-propulsion in maintaining its assigned GPS coordinates. Or, in case of a vehicle which had been assigned a flight path; navigate to keep to the designated trajectory. Such UAS; UUS capabilities avoids interference; collision; damages; in



between a multitude of different apparatus or vehicles in an energy extraction/or conversion farm **300ax**.

FIG. **8C** illustrates a variant drone HAV-**800b** of FIG. **8A** and FIG. **8B**; integrated with a variant, ultra-light-weight (and thus a much larger sized) wind powered turbine generator **500vax**. Wherein said wind powered turbine generator **500vax** may be configured alike apparatus **500aax**. Optionally, wind powered turbine generator **500vax** and drone **800a** may be configured comprising solely of ultra-light-weight materials. The blades **492ax** of wind powered turbine-generator **500vax** may comprise of: composites materials; plastics; carbon-nano-fiber; fiberglass; Kevlar; etc. embedded with rotor wires **488ax** and rotor magnets **489ax**. Optionally, all turbine blades **492ax** may be coated externally with layers of specialty water-proofing materials **806**; protecting said delicate and sensitive generation elements **488ax** and **489ax** embedded within; integrated internally into said blades. A drone with a smaller body and multiple units of propulsion turbines **70ax** (8 units) directly attached to wind powered turbine-generator **500vax** may be configured. Wherein said rotor rings of wire coils **493ax**; and magnets **494ax** may be replaced or substituted by means of embedded generating elements comprising: rotor wire coil **488ax**; and rotor magnets **489ax**; directly integrated, impregnated and structurally incorporated into the turbine blades **492ax** of wind powered turbine generator **500vax**. (refer FIG. 4H; FIG. 5A to FIG. 5K of U.S. patent Ser. No. 10/113,534).

Turbine generator **500aax**; **500vax** may comprise of dual units of turbines placed in close proximity to each other, in an over-under (top-bottom; horizontal position) configuration; or in a side by side configuration (vertical position). (Refer to FIG. 4H; FIG. 5I; FIG. 5J of parent U.S. patent Ser. No. 10/113,534.) Wherein with the body of drone HAV-**800b** preferably aligned in an inclined position (FIG. **8B**); said twin units of turbines counter-rotates against each other in close proximity (one unit turning clock-wise; with the other unit turning in an anti-clockwise direction). Said generating elements: wire-coils **488ax**; magnets **489ax**; directly embedded into said counter-revolving turbine blades **492ax** located bottom and top (belly and hind) moving past each other in proximity, at very high velocities generating electricity.

FIG. **8D** illustrates a variant self-propelled aerial drone HAV-**400vax** integrated with a plurality of motorized turbofans **70ax**; in addition to propulsion engine **408ax**; as previously disclosed in U.S. Pat. No. 10,113,534. Additional propulsion units **70ax** may be configured directly onto the body of HAV-**400vax**; just like HAV-**800b** of FIG. **8C**. Equipped with these motorized propulsion units **70ax**; the self-propulsion capability of HAV-**400vax** is enhanced. Drone HAV-**400vax** is now fully self-reliant; and achieved independence from its previous reliance on Unmanned Aerial Tug Vehicles, UATV-**80aaa**; **80aab**; **80aac** for VTOL and ascent purposes.

FIG. **8E** to FIG. **8G** illustrates a morphing drone HAV-**800c** of FIG. **8A** configured with dual sets of wings. FIG. **8E** illustrates a plan view; FIG. **8F** illustrates a sectional front view of a retracted drone; FIG. **8G** illustrates the frontal view of a fully extended drone. One set of wings **69bax**; (**404bax**); located at the bottom; with a smaller set of wings **69tax**; (**404tax**); stacked above in an over-under configuration of the bi-planes (of olden days). The twin sets of top and bottom wings **69tax**; **69bax**; may be held together by means of: extendable-retractable apparatus; extendable-collapsible mechanisms; stretchable-foldable members; such as jacks **807** and mechanical arms **808** driven by pneumatic and/or hydraulic systems.

The space in between the top and bottom wings may be mounted with a wind bag **30ax** and a wind-turbine-generator **500aax**; or a tidal-turbine-generator **500aax**. Including extendable-collapsible pneumatic arms **807**; hydraulic arms **808**; or other mechanisms to vertically open up; or to close and collapse (the distance between) the top and bottom wings **69tax**; **69bax** of drone bi-plane **800c**. Pneumatic arms **807**; **808** may also be configured for mounting and supporting turbine-generator **500aax** and windbag **30ax**. When the wings are in open position, a large space is created for said built-in windbag **30ax** and turbine-generator **500aax** to operably deploy and function as configured. Windbag **30ax** may be configured with other high velocity wind-turbine-generators: **500bax**; **500cax**; **500dax**; located aft to generate electricity. (Refer FIG. 5A to FIG. 5M of U.S. patent Ser. No. 10/113,534). Whereas, wind entering the large square shaped cavity **25ax** of inlet port ring **22ax** (fore) may be channeled through a narrower outlet port **809** (aft) integrated with turbine-generator **500aax**; thus accelerating its velocity as it passes through the blades **492ax** of turbine-generator **500aax**. Such a configuration illustrates the use of a high altitude self-propelled flying drone HAV-**800c** integrated with a shrouded (windbag **30ax**) wind powered turbine-generator **500aax**; **500vax**. Flying wind turbine-generator **500aax** may be collapsed, horizontally positioned when not in use; such as during the flight mode (ascent; descent). During the generation mode it may be aligned vertically; or at an optimally inclined angle; when the top and bottom wings **69tax**; **69bax**; opens up. This may be enabled by means of supporting hydraulic arms **807**; **808**; mounted in embedded sliding brackets and grooves **810**; and/or other like specialty mechanical accessories customized for their specific utility purposes. Inlet port ring **22ax** may follow the square shaped contour of the hydraulic arms **807**; **808**. It may also be configured to be of any practicable shape or size. Operably opened and closed by means of pressurized air; in sync with mechanical arms **807**; **808**; movement, etc. (Refer apparatus **620d** of FIG. **3A** to FIG. **3E**.)

FIG. **8H** to FIG. **8J** illustrates a variant morphing drone bi-plane **800d** of FIG. **8E** to FIG. **8G** with dual sets of similar sized wings **69tax**; **69bax**; (**404tax**; **404bax**) mounted in an over-under (top-bottom) configuration. FIG. **8H** illustrates the plain view of drone **800d** in flight mode with the wings aligned fore and aft. FIG. **8I** illustrates the front view of drone **800d** in generation mode with said wings aligned top and bottom (over-under). FIG. **8J** illustrates the side view. A plurality of pneumatic jacks **807**; or appendages **808** (3 units) operably connected said top and bottom wings **69tax**; **69bax**; keeping them together.

In the flight mode, the bottom set of wings **69ax**; **404tax**; may be flipped backward and upward by means of appendages **807**; **808**. With both sets of wings parallel to each other at nearly the same level. The collapsed windbag **30ax** integrated with turbine-generator **500aax** may be positioned horizontally with the windbag materials folded and stored by means of a plurality of: sliding lines **23ax**; **66ax**; accessories **67ax**; **68aax**; line winches **59ax**; etc. for controlling; releasing; retracting; said windbag; wingsuit; fabric materials. In such a fore-aft arrangement; all of the four main propulsion turbines **70ax** may be fully utilized for maximum creation of vertical lift.

When drone **800d** attained cruising height; bottom wings **69bax** may be lowered downward and flipped forward by means of appendages **807**; **808**; forming a normal bi-plane's over-under (top-bottom) wings configuration. Such a maneuver opens up a large space in between the two sets of bi-plane's wings **69tax**; **69bax**; for windbag **30ax** and tur-



bine-generator **500vax** mounted in between said top and bottom wings to function. Operably capturing high altitude wind current; transforming its kinetic energy **11ax** into electrical energy. As the top and bottom wings opens up; spreading apart; turbine **500vax**, lying in a horizontal position on top of bottom wings **69bax** may be moved by means of said pneumatic arms **807**; **808**; sliding along built-in grooves **810**; into an upright, vertical position (generation mode). Wind current captured by bag **30ax** may be directed into wind turbine-generator **500aax**; **500vax**; driving, powering it to generate electricity. Windbag **30ax** may be securely mounted in groove **810** embedded into the wings structure.

A comparison may be drawn with reference to a normal large sized open flow turbine-generator **800b** of FIG. **8C**; versus **800d** of FIG. **8H** to FIG. **8J**. Said smaller sized apparatus **800d** may be much more productive than a larger sized apparatus **800b**. Because a shrouded or hooded (windbag **30ax**) apparatus operates at higher velocities; thus higher efficiencies  $C_p$  (approx. 2 to 3 times); as compared to an open flow apparatus. A similar comparison maybe drawn between the dotted lines in FIG. **8I** versus the solid lines **809**. Said dotted lines may be used to denote the body of a much larger apparatus **500vax** in open flow (without bag). Whereas solid lines **809** denotes the joining point between the outlet port **809** of windbag **30ax** and the body of a smaller apparatus **500vax**; integrated with windbag **30ax**. Windbag **30ax** forms a wingsuit; shroud or hood improving efficiency of apparatus **500vax**. Wherein integration of windbags **30ax** with turbine generator **500vax** enables deployment of a much smaller and lighter turbine generator **500vax** with much higher efficiencies. Since an enclosed, shrouded turbine-generator **800b** will be much more efficient than an open-flow system; a hood of whatever size or shape, may also be configured for use at the fluid inlet port of apparatus **500aax**; **500vax** of HAV-**800a** and HAV-**800b** of FIG. **8A** to FIG. **8C**.

FIG. **8J** illustrates the side view of drone **800d** wherein said twin set of wings **69tax**; **69bax** may be configured, intentionally manipulated or adjusted to form a tapered, funnel shaped aerial apparatus from fore to aft. With a large inlet port **25ax**; and a small outlet **809** integrated with the periphery of wind turbine-generator **500vax**. For aspirating a large volume of wind at the inlet port **25ax** formed by pneumatic arms **807**; top and bottom wings; and inlet port ring **22ax**; flowing via a smaller outlet port **809** of windbag into the turbine blades **492ax** of wind turbine generator **500aax**; **500bax**; etc. before exiting aft, discharged to the atmosphere. Wherein said funnel shaped shroud or hood formed by windbag **30ax**; constricts and accelerates the flow of wind and water currents; concentrating; enhancing its velocity through turbine-generator **500aax**; or an ultra-light-weight turbine-generator **500vax**.

RAT-**71ax** mounted on body **77ax** may generate onboard power and compressed air for inflation of inlet port ring **22ax**; air-ribs **277ax** of windbags **30ax**. Electrical power generated on-board by means of RAT-**71ax**; and wind turbine-generator **500aax**; **500vax** may also be used to power the plurality of propulsion turbines **70ax**. Excess power generated may be transmitted by means of a variant conductive tether **50vax**; anchor line **46vax**. Power for initial take-off and make up power for propulsion turbines **70ax** may also be supplied by means of said variant conductive tether **50vax**.

FIG. **8K** to FIG. **8M** illustrates a variant configuration of FIG. **8A** to FIG. **8J** wherein said drone HAV-**800e**; HUV-**800e** may be equipped only with a windbag **30ax** (drive unit

**51ax**) for traction-generation of renewable electricity by means of tether **50aax** and driven unit **55ax**; akin to system HAV-**100ax**; HUV-**200ax**; HUV-**400ax**; **222ax**; **76ax**; etc. FIG. **8K** illustrates the plain view. FIG. **8L** illustrates the frontal view of **800e**; in flight mode with windbag **30ax** retracted and kept closed by bottom body frame **811**. FIG. **8M** illustrates the frontal view of **800e**; in generation mode with an extended windbag **30ax** by an open bottom body frame **811**. Windbag **30ax** with a large inlet port **22ax** framed by extendable retractable parts **807**; **808**; tapers towards a small enclosed rear end (cone-shaped). RAT-**71ax** may be used for self-generation of utilities abroad comprising electricity and compressed air enabling prolonged periods of deployment. Optionally, RAT-**71ax** may also be connected to outlet port **809** and driven by means of fluid exiting windbag **30ax**; turbine-generator **500vax** (apparatus **800c** and **800d** in FIG. **8E** to FIG. **8J**). Apparatus **800e** may also be used for traction purposes; and propulsion of vehicles comprising: boats; ships; sledges; wheeled vehicles; etc. over terrain comprising: water; sea; ice; snow; etc. for solo trips; expeditions; or commercial purposes. And at the same time supplying power to the surface crew and equipment.

FIG. **8N** illustrates the utility purpose of a plain and basic drone vehicle HAV-**800** in leading, controlling and commanding a multitude of windbags **30ax**; or water-bags **40ax**; wherein, said plurality of bags may be configured in series, one bag after another bag as previously disclosed in system **222ax**; **76ax**. Said self-propelled drone HAV-**800** may or may not carry a turbine-generator **500aax** or a windbag **30ax** on its body. Since its main purpose is working as a master controller; leading a pack of fluid entrapping bags (slaves) attached to tether line **50ax** (drive unit **51**). For the sole purpose of traction-generation-production of renewable electricity in association with driven unit **55ax**. With reference to FIG. **6P** and FIG. **6Q** of U.S. patent Ser. No. 10/113,534; HAV-**800** may also be used with bridle lines **21ax** attached at points **803**; **804**; **805**; connected to tether line **50ax** at point **31ax**; controlling a multitude of bags **30ax**. A retract line **33ax** and winch **59ax** maybe used for depowering of said apparatus **76ax**; **222ax**. Drone vehicle may use its propulsion systems **70ax** for active depowering of said apparatus or system **222ax**; **76ax**. Said drive unit **51ax** powering a ground mounted driven unit **55ax**.

FIG. **8'O'** illustrates a variant configuration of FIG. **8N** wherein, said plurality of bags constituting system **76ax**; **222ax**; may comprise of a multitude of HAV-**100ax**; or HUV-**200ax** lead by a master-controller drone comprising a variant unit of: HAV-**800**; HUV-**800**; or HAV-**100vax**; HUV-**200vax**. Said master-controller drone **800** may be equipped with homing sensor **812**; located near to the tip of its nose cone. Sensor **812** is configured to home in on signals emitted by a homing-signal generator **813**; attached at a desirable location **814**; in proximity to an attachment ring **815**; on main tether line **50ax**. Generator **813** may constitute a homing-signals generator comprising: radar; GPS; a transponder system; x-rays; radio-waves; sonars; visual-audio signals; etc. Such an interactive transmission and reception signaling-homing system may be used during the depowering phase of system **76ax**; **222ax**. Wherein, at the end of its power generating run (point **288ax**), said master-controller drone vehicle **800**; **100vax**; **200vax**; may be remotely commanded; or pre-programmed by means of computerized systems and artificial intelligence (AI); to turn around; thereby spilling the fluid content entrapped by said bags; depowering them. In proximity to device **813** located at point **814** said master-controller drone may use optical-visual signals captured by means of onboard precision

cameras **816** to seek-out; locate and then, latch tightly onto a ring **815** by means of a suitably configured attachment apparatus **817**; or a locking device **817**; located at the tip of its fore nose-cone. Sensor **812**; camera **816** and locking device **817** may be located in proximity to each other. Components of apparatus **817** may operably open up; clamp; grip; lock tightly onto ring **815**. Optionally, apparatus **817** may also be configured to slide open, insert ring **815** into its orifice or port and close back securely. An example being: industrial grade spring-loaded shackles or carabiners; operated by means of electro-mechanical cum magnetic mechanisms controlled by computerized logic or artificial intelligence (AI) sequence. Tether line **50ax** may then be retracted back to the starting point **16ax** by means of rewinding motor **49ax**. Such a structural configuration may not require the use of an independent retract line **33ax** and line-reel system **R49ax**; or the use of a winch **59ax** (onboard drone vehicle) and retract line **33ax** system attached onto tether line **50ax** (refer FIG. 11A to FIG. 11J of U.S. Pat. No. 8,963,362).

FIG. 8P illustrates a variant configuration **800f**; wherein apart from previously disclosed propulsion means of HAV-**100vax**; HUV-**200vax** comprising one singular unit (**70ax**; **240ax**); said drones maybe equipped with additional units of propulsion means comprising: a multitude of said motorized turbo-fan units **70ax**; multiple propeller units **240ax**; cum much larger control surfaces **69ax** strategically located on said aero-dynamically shaped vehicle body: **77ax**; **99ax**; **201ax**. Control surfaces **84ax**; **85ax**; may be used with aerodynamically shaped body **99ax**. Hydroplanes **205ax**; **206ax**; **207ax**; **208ax**; may be used with hydro-dynamically shaped body **201ax**. Previously HAV-**100ax** relies on a group of means comprising: one single motorized propulsion unit **70ax**; flexibly attached UATV-**80ax**; light-than-air (LTA) gases comprising: helium; or hydrogen in body **99ax**; **201ax** to achieve aerial lift and buoyancy. Wherein with 100% motorized self-propulsion by means of **70ax**; **240ax**; said HAV-**100vax**; HUV-**200vax**; need not rely on the use of: UATV-**80ax**; or on lighter than air (LTA) gases. Optionally, continued usage of LTA gases helps in providing lighter propulsion-engine loads; and minimized energy consumption. LTA gas may be augmented by modified flight control surfaces **69ax** and **820** which may be enlarged and elongated. Such multi-functional capabilities in using multiple propulsion units **70ax**; tug-vehicles **80ax**; LTA gases; wings **69ax**; **820**; enhances operational flexibilities of said variant drone vehicles. Wings, hydroplanes and control surfaces may be modified. Configured to be tilt-able; and to rotate to adjust a vehicle's lift; drastically altering said wings leading edge's angle of attack speedily; etc. relative to wind and tidal current flow. Wherein, said wings **69ax** may be split or divided **818** into two components comprising: a normal fixed wings portion **69ax**; and a rotatable, tilt-able wings portion **820**; inter-connected by means of an internal shaft **819** in between said dual split portions. Said portion **820** may be adjusted variably to tilt at an angular inclination dictated by means of software commands from computerized AI flight software abroad; providing optimized aerodynamic lift generation (relative to wind direction) for extended periods of time. Such a configuration minimizes use of propulsion units **70ax**; which consume energies. All apparatus of present inventions may be configured with fixed and variable wings and control surfaces for generation of aero-dynamic lift for extended periods of time. Example: for weeks; or, months; as in FIG. 8A to FIG. 8J; FIG. 8Q; FIG. 9D. Main motorized propulsion units **70ax**; **240ax**; may be used mainly for vertical-take-off and landing (VTOL); and for standing by. Auxiliary unit **70ax**; **240ax**; maybe kept

on hot standby; or on active service for vehicle adjustments to cater for shifting wind conditions.

FIG. 8Q illustrates a variant apparatus **800g** of FIG. 8E to FIG. 8J. Wherein, said drone apparatus may comprise of 3 body portions. One main body **77ax** in the middle; hemmed in by two smaller supporting bodies **77pax** port; and **77sax** starboard. Joined together by means of an extended wings structure **69ax**; extending from the port side **69pax**; and starboard side **69sax**. Said bodies **77ax**; **77pax**; **77sax**; being operably used to control deployment; and/or extension of an integrated windbag **30ax** cum wind turbine-generator **500vax** located aft. Windbag **30ax** may be affixed in grooves **810** of the wings; and may utilize a plurality of sliding lines **23ax**; **66ax**; accessories **67ax**; **68aax**; line winches **59ax**; etc. for controlling; releasing; retracting; said windbag materials. (Refer FIG. 3H to FIG. 3I of U.S. Pat. No. 8,963,362). Wind entering said inlet port **25ax** passes through turbine-generator **500vax** located aft; before exiting through outlet port **821**. Wingsuits **30ax** may also be used for fluid entrapment.

FIG. 9A and FIG. 9B illustrates a variant apparatus **800h**. FIG. 9A illustrates a perspective side view; while FIG. 9B illustrates a plain view (topside **802**) of a said apparatus **800h** wherein said turbine-generator unit **500aax**; **500vax** may be integrated with a plurality of motorized propulsion units **70ax** mounted on struts **818** with a fabric shroud **30ax** or hood **30ax** extended around the circumference of said turbine-generator **500vax**. Fabric shroud **30ax** may be directly attached to the circumference of said turbine-generator **500vax**; extending outward like a wingsuit **30ax** supported by a plurality of structural members comprising struts **822**. Bags and shrouds functions like wingsuits in engaging wind current; just like the extended membranous skin of a bat's wings. Channeling, diverting said wind flow into the turbine-generator unit **500vax**; from an enlarged inlet port **25ax** via inlet port ring **22ax**; into the belly **801** of apparatus **800h**, through turbine blades **492ax**; before exiting from the topside **802**. Struts **822** may be configured extending directly from the body of apparatus **500vax**; connecting with flexibly adjustable joints **823**; and extended into short portion **822'**; which may be used as legs for landing and take-off of apparatus **800h**. Adjustable joints **823** in between main struts **822** and leg portions **822'**; may be configured for mounting flexibly positioned propulsion units **70ax**. Flexible joints **823** may be fitted with suitably configured; customized specialty accessories enabling it to function as desired. The position of propulsion units **70ax** may preferably be aligned horizontally in order to maximize lifting duty. A plurality of bridle lines **21ax** connected to and extending from legged portions **822'** of struts **822** joined tether line **50vax** at point **31ax** kept said apparatus **800h** in position. Wherein, said unit **800h** may be lofted into high altitude by means of said propulsion units **70ax**. Aligned at an inclined position such that wind and/or water current flows from the bottom or belly **801** (refer FIG. 8B) of said apparatus; through the turbine blades **492ax**; exiting from the hind or top-side **802** of said unit **500vax**. Fabric shroud **30ax** at the periphery of unit **500vax** entrapped and channeled wind and water current from an enlarged inlet port **25ax** through the narrower outlet via unit **500vax**. Likewise said unit **800h** may also be configured for use in an ocean or seaborne environment to harness tidal energies; wherein said motorized propulsion units **70ax** provides directional controls; while the buoyancy of the entire apparatus **830ax** may be controlled by means of airbags **202ax**; lines **204ax** and compressed air cylinders **203ax**; sinkers and diving weights **221ax**. Components: **676**; **677**; **678**; **679**; **681**; **682**; **683**; **684**; constituting system **686** of FIG. 3L above may also be

used. Power generated by apparatus **500vax** may be transmitted by means of a conductive tether **50vax**. Turbine-generators **500aax**; **500vax**; may also be substituted or replaced by other like apparatus disclosed in the specifications: **471ax**; **617**; **472ax**; **500bax**; **500cax**; **500dax**; etc.

FIG. 9C illustrates the perspective view of a variant apparatus **800i** of FIG. 9A and FIG. 9B; wherein said turbine-generator unit **500aax** may be replaced by; or substituted with a windbag unit **30ax** mounted on an aerodynamic body **100vax**; or, a hydrodynamic body **200vax**; and connected by means of a plurality of bridle lines **21ax** to a winch **59ax**. Said bag **30ax** may be integrated with peripheral mounted shroud or wingsuit **30ax**. Structural body **100vax** or **200vax** may in turn be connected by means of tether **50vax** (drive unit **51ax**) to a surface based driven unit **55ax**. Said drive unit **51ax** provides traction-generation capability in tandem with a said driven unit **55ax** to produce renewable electricity. (Refer apparatus **800e** of FIG. 8K to FIG. 8M). The framework of struts **822** may be extended from the motorized propulsion turbine units **70ax** to the fore (bow) of the apparatus **800i**; providing it with mechanical capability to open and close the shroud formed by windbag and wingsuit **30ax**; by means of pneumatic mechanisms mounted on its body **77ax**; **99ax**; **201ax**. Said body maybe configured to include a Ram-Air-Turbine (RAT) **71ax** mounted at the bow providing compressed air to operably control (open or close) the inlet port ring **22ax**; air-ribs **277ax**; struts **822** of said windbag **30ax** as and when required. High velocity wind may enter RAT-**71ax** via inlet port **824**; exiting via outlet port **825**. RAT-**71ax** may also be configured to supply electricity to power turbines **70ax**. Enabling apparatus **800i** self-sufficiency in generation of energy and propulsion power. Wherein apparatus **800i** may operably generate its own power to run, to propel turbines **70ax**; keeping itself airborne for extended periods of time. Any power shortfalls may be made up for by means of conductive tether **50vax** from surface based backup means. A pressurized air blower **826** may be used for augmenting take-off and landing of system **800** apparatus. Discharge nozzle **826** may be coupled with compressors; compressed air tanks; air lines; etc.

FIG. 9D illustrates the perspective view of a variant apparatus **800j**; wherein said components of a self-propelled flying turbine-generator **800h** (FIG. 9A; FIG. 9B) may be integrated with components of a HAV-**100vax**; or HUV-**200vax** (refer FIG. 8P). Forming a variant self-propelled hybrid turbine-generator apparatus: HAV-**800j**; HUV-**800j**. Wherein said rotor-rotor turbine-generator may comprise of: **500aax**; **500vax**; **500bax**; **500cax**; etc. configured with their embedded electrical and magnetic elements waterproofed and externally sealed; covered in a robust layer of protective materials comprising: plastics; ceramics; glass; carbon-fibers; composite materials; etc. Optionally, it may also comprise of a normal; standard rotor-stator turbine-generator **471ax** (refer FIG. 4A of U.S. patent Ser. No. 10/113,534). Wherein components of said modified turbine-generator **471ax** may be directly embedded and integrated into the body **99ax**; **201ax** structure (FIG. 9E). The relative position or location of components may be shifted or reconfigured to optimize operability of such a hybrid apparatus HAV-**800j**; HUV-**800j**.

FIG. 9E illustrates an optional configuration wherein the generation components **471ax** of said HAV-**800j**; HUV-**800j**; in FIG. 9D may be integrated into; forming; becoming part of the structural body **99ax**; **201ax**. The extremely sensitive wire coil **474ax** (**488ax**) of said modified turbine-generator **471ax** may be configured: concealed inside the body **99ax**;

**201ax** structure. Totally segregated from the external surroundings by means of said structural arrangement. Wherein said concealing; protective layer comprises of the solid state body **99ax**; **201ax** of HAV-**100vax**; HUV-**200vax**. Whereas, said rotor coil **474ax**; rotor magnet **476ax** (**489ax**) maybe embedded; impregnated; encased; insulated; isolated; in layer(s) of laminating composite materials **806**. Rotor coil **474ax**; rotor magnet **476ax** (**489ax**) may also be configured; separated from each other by said body structure **99ax**; **201ax**. Wherein said coating comprising layers of protective water-proof materials **806** provides functionality of the apparatus; and protection against moisture and corrosion (refer FIG. 15A to 15C; U.S. Pat. No. 8,963,362). The rotational movement of said rotor magnets ring **476ax**; directly attached to turbine blades **492ax**; may be assisted by a bearings assembly **597ax**. Variant HUV-**200vax** may be configured wherein the shroud comprising water-bag **40ax** entrapped and diverted tidal flow into a turbine **471ax**; mounted in the center around body **201ax**. HUV-**200vax** may be tethered and affixed to the seabed **537ax**; tilted in the direction of tidal current flow; entrapping said fluid; channeling it into turbine **471ax**; to generate power. Power generated may be routed from the generating wire coils **474ax**; via aft (stern) mounted conductive tether-cable **50vax**; to seabed mounted cable attachment point **764** (FIG. 5K); for transmission to surface buoy **508ax**; ballast tank **578ax**; or to shore. Power generating nacelle **611** of turbine-generator **617** of body **201ax** may be made of compatible composite materials; said layer(s) of composites enabling; ensuring magnetic field from externally located magnet penetrates through the layer with ease; and reaches the wire coils mounted inside body **201ax**. Optionally, the body-wall **99ax**; **201ax** of nacelle **611** of turbine-generator **617** may be made slightly thinner to enable enhanced penetration of magnetic field and power generation. Supporting rings **828**; or other structures may be used to secure turbine **500aax** to body **99ax**; **201ax**.

FIG. 10A illustrates a planetary-gears apparatus **830** integrated with a variant counter-rotating generator **777v**. FIG. 10B illustrates a plan view of apparatus **830**. FIG. 10A illustrates a side-sectional view of an arrangement wherein a planetary gear **830** may be suitably configured with a torque transmission gearbox **583ax**; main shaft **581ax**; to work with a single unit of variant counter-rotating generator **777v**; or, a variant generator **585ax**; **590ax**; configured with only one single source of torque (input); with two opposing torques (outputs) to power dual rotor coil **474ax** and rotor magnets **476ax**. Planetary gear apparatus **830** may be configured and used for the conversion of rotational mechanical energies (torque). Wherein, a single source of torque transmitted (from gearbox **583ax** to main shaft **581ax**) may be transformed from one rotational direction: e.g. clockwise (input); into an opposite rotating direction: e.g. anti-clockwise (output); by means of apparatus **830**. Such that said original torque (rotating clockwise) may be combined with the derived torque transformed by means of apparatus **830** (rotating anti-clockwise) to drive the: rotor coils **474ax**; and rotor magnets **476ax**; of counter-rotating generator **777v**. Apparatus **830** enables the conversion and transformation of one single stream of torque energy into two opposing streams (directions) of torque; and may be suitably configured for use with apparatus **777v** of present invention. Wherein said counter-rotating streams of torque energy (turning moment) may then be used to drive; to power a counter-rotating generator unit **777v**. One stream of torque (original input of main shaft **581ax**, turning clock-wise) may be configured to power the rotor magnet **476ax**. While the

other, derived stream of torque (produced by apparatus **830** connected to the yoke **484ax**, turning anti-clock-wise) may be configured to power the rotor coil **474ax** of generator **777v**. Or, vice-versa.

Planetary gear apparatus **830** may comprise of: a central gear **829** mounted on the central shaft **581ax** (bearing the original torque: input); ringed by a plurality of transmission gears **831**; surrounded by a peripheral gear ring **832**. The turning moment transmitted by center gear **829** (input); is transmitted to gears **831**; then on to peripheral gear ring **832**. The movement of gear ring **832** is reversed by means of this derived torque transmission; which may be further transmitted by means of a plurality of yoke **484ax** to power rotor coils **474ax**. Central shaft **581ax** transmitting the original torque (input) may directly be configured to power rotor magnets **476ax**.

Such an apparatus **830** may be used when a large amount of torque produced by a single apparatus (for example: a large wind turbine with 10 MW output) may be transformed and spilt into two streams (example: 5 MW of torque each) for powering one generator unit **777v**. Assuming that a normal (rotor-stator) generator configured for said 10 MW turbine had a size; weight of "X". An equivalent (rotor-rotor) generator unit **777v** may be configured to have a size or mass of "half X" (" $\frac{1}{2}X$ "). Since rotor-rotor (rotor coil; rotor magnet) configuration may be translated into reduced generator mass; or size of generating elements; as compared to rotor-stator configuration. It is (will be) definitely advantageous for a generator half of its normal size or mass to be installed inside its nacelle **473ax** atop turbine pillar **469ax** hundreds of meters high. And even better still, if this " $\frac{1}{2}X$ " is removed and shifted from the top nacelle **473ax** down to the surface level (ground or platform **741**). With generated torque transmitted by means of extended shaft **692**.

Wherein, counter-rotating generator unit **777** may be configured to be driven by: (1) one source of torque transformed into twin streams of opposing torques by means of planetary gears **830**; to drive a variant generator unit **777v**. (2) Two streams of torque transmitted from two individual drive units. (3) A multitude of torque streams transmitted from diverse wind and tidal energy conversion apparatus (drive units **51ax**) may be configured to drive; and power individual (segmented) generation sections: **777**; **777'**; **777''**; etc. Wherein said generation sections **777**; **777'**; **777''**; etc. may operably be used individually. Or, specific components (e.g. rotor magnets **476ax**; or rotor coils **474ax** mounted on main shaft **581ax**) may operably be combined together by means of gear-clutch mechanisms **587ax** (drive unit **51ax** of similar ratings; matching output; etc.) Apparatus **587ax** may comprise fully automated variable speed gears; semi-automatic gears; manual gears. Such flexibility and versatility in configuration enables optimized efficiency and productivity of system **777**; in response to natural variability of the elements—wind and tidal resources.

FIG. **10C** to FIG. **10E** illustrates three variant tidal turbines: **471vax**; **768v**; **768w**; derived from the floating, buoyant tidal turbine system **768** of FIG. **6B**; and features disclosed in FIG. **9E**. FIG. **10F** illustrates use of said plurality of turbines. FIG. **10C** illustrates a variant floating dual-units (fore-aft) tidal turbines **617v**; **471vax** (refer FIG. **4A**; U.S. patent Ser. No. 10/113,534) wherein moisture sensitive generating components comprising: rotor coils **474ax**; rotor magnets **476ax**; may be segregated and isolated from direct contact with water; as disclosed in FIG. **9E**. Embedded; integrated into; encased in layer(s) of composite materials comprising: plastics; ceramics; glass; carbon fibers; Kevlar; Dyneema; Teflon; etc. Generating mecha-

nisms may be configured with standard rotor coil cum stator magnet (or vice-versa). Or, it may consist of counter-rotating "rotor-rotor" configuration comprising: rotor coils cum rotor magnets. Direct conversion of kinetic to mechanical to electrical energies occurs in the buoyant body **767**; nacelles **611**; **473ax**; of the tidal turbine **617v**; **471vax**. Electricity generated may be transmitted by means of variant undersea tether-cable **457vax** to the surface based floating platform **741**; **747**. Buoyant tidal turbine **617v**; **471vax** may be configured to be: buoyancy neutral; or, with positive buoyancy; dependent upon inflation of air-filled **683** buoyancy bodies **767**; nacelle **611**. Additional buoyancy may be enabled by means of inflatable body **202vax**; attached to body **767**; or nacelle **611**. Control surfaces comprising vertical fins **206ax**; horizontal fins **207ax**; may be used for orientation and self-balancing. Vertically oriented struts **691** connected the body **767**; nacelle **611** via vertical fins **206ax** to swivel mechanism **643**; and variant tether cable **457vax** to surface platform **741**; and the bottom submersible vessel **230vax**.

FIG. **10D** illustrates a variant floating tidal turbine **768v** of FIG. **6B**; comprising of a dual-units (fore-aft) tidal turbines **768v** wherein, mechanical energies derived from said conversion of kinetic energy (tidal flow) by tidal turbines **768v** may be transmitted from said apparatus by means of gear-boxes **583ax**; vertical shafts **691** residing in vertical fins **206ax**; swivel mechanism **643** or universal couplings **666**; extended shaft **692**; to the driven units **777**; **54ax**; etc. One driven unit **777** may be located on surface based floating platform **741**; one driven unit **777** located on the seabed **537ax** (refer FIG. **10F**). Electricity produced by the surface **741** and seabed **537** based generators may be transmitted by means of undersea cable **457ax** laid in cable trench **789**; to shore facilities **622**. Integration of vertical shafts **691** into the vertical control surfaces **206ax** enables creation of a large clearance angle for tether-cables **457vax**; or extended shafts **692**; to operably change its angle of inclination; without interfering with turbine blades **472ax** operability. Horizontal control surfaces **207ax** helps to keep the body **767** in level position parallel to the tidal current flow.

FIG. **10E** illustrates a variant floating tidal turbine **768w** of FIG. **6B** and FIG. **10D**; comprising of a single unit of tidal turbine **768w** wherein, said apparatus may be configured to generate torque; or electricity. Configured with rotor coils **474ax**; rotor magnets **476ax** in nacelle **473ax**; **611**; of FIG. **10C**; said apparatus **768w** may produce electricity which may be transmitted safely by means of: an inclined variant tether-cable **457vax**; integrated into and passing through the vertical fins **206ax**; to surface sub-station **622**. Configured with a torque transmission system **687**; mechanical energies derived from said conversion of kinetic energy (tidal flow) by apparatus **768w** may be transmitted by means of: gear-boxes **583ax**; inclined extended shafts **692** residing in, integrated into and passing through specially adapted passage **833** in the vertical fins **206ax**; universal couplings **666**; to the driven units **777**. Such a configuration enables transmission of torque or electricity produced by said turbine **768w** without interfering with the turning turbine blades **472ax**.

FIG. **10F** illustrates the use of said floating tidal turbines **768v**; **768w** and **471vax** (**617v**). Variant sub-system **580uax** (refer FIG. **6Y**; U.S. patent Ser. No. 10/113,534) illustrates a plurality of tidal turbine **471vax** (**617v**) anchored by means of variant tether-cable **457vax**. Top end of line **457vax** may be anchored to winched **49ax** line reel **52ax** drums on surface platform **741**. The bottom end may be anchored to a UUV-**230ax**; or a variant submersible vessel **230vax**; which

may submerge or surface upon command by means of remote signals. Enabling precision controls in position; location; depth; and deployment of multiple apparatus **580uax**; **580vax**; **580wax**; etc. from surface vessel **741**. Vessel **230vax** may also be controlled to adjust the angular inclination of line **457vax**; its slackness; taunt-ness; stress or strain for operational purposes. Line **457vax** may preferably comprise of double lines closed loop configuration (refer FIG. 6'O' system 510u; U.S. patent Ser. No. 10/113,534); for ease of periodic checking; maintenance and repair purposes. Variant sub-system **580vax** illustrates a plurality of dual tidal turbines **768v**; or single tidal turbine **768w**; anchored by means of extended shaft **692**. Top end of extended shaft **692** may be anchored to a generator **777**; **585ax**; **590ax**; **54ax**; on surface platform **741**. The bottom end may be anchored to a hermetically sealed generator **777** mounted on concrete slab **653** on the seabed **537ax**. Mothership **741** may be configured with specialized structures **834** for housing said generators; winching equipment; control systems; etc. for handling said variety of submerged tidal turbine arrays.

FIG. 10G illustrates a variant floating-submerged tidal turbines sub-system **580wax** wherein said multiple units of turbines comprising: apparatus **471vax** (**617**); **768w**; **500vax**; **500aax**; etc. may be strung together; connected by means of conductive-tether line **457vax**. The bottom end of tether **457vax** may be anchored to a piled **562ax** concrete base **653** on the seabed **537ax**; the top end may be secured to a submersible vessel **230vax**. Said submersible vessel **230vax** may be configured to submerge below surface level **621** when in operation. And to surface whenever required for periodic maintenance checks and repair. Minimizing surface footprint of the entire apparatus **580wax**; posing zero interference to shipping. A small marker buoy **508ax** tethered on the water surface **621** may be used to indicate the location of apparatus **580vax**. Said array **580wax** may also be configured with buoyant turbines, or buoyancy neutral turbines: **768**; **768v**; **768w**; **471vax** (**617v**); xxx; etc.

Submersible vessel **230vax**'s buoyancy maybe controlled by means of system **690ax**; sub-system **686** of FIG. 3K to FIG. 3L; enabling the entire apparatus **580wax** to surface; or to submerge upon remote command; by means of Unmanned Underwater System (UUS) of communication; tethered or untethered. Sub-system **686** enables creation of variable buoyancy to countenance, to neutralize the swift effects of tidal flow changes; to adjust variable angle of incline of the variant conductive-tether line **457vax** for optimal system performance by means of AI commands; control surfaces **206ax**; **207ax**. Wherein said tether line **457vax** connected to winched **49ax**' line reel **52ax**' mounted on the body of submersible vehicle **230vax** may be operably controlled enabling apparatus **230vax** to surface or to submerge. Such maneuverability enables multiple arrays of apparatus **580wax** to be deployed in proximity from a cluster of anchoring points on concrete pads **653**. Such that said multitude of floating-submerged arrays **580wax** may be arranged in a fore and aft; port and starboard position; or, at inclined angular positions; downstream (tidal flow) of concrete pads **653** on seabed **537ax**.

A single line **457vax** may be used where applicable. But a closed loop (twin) lines **457vax** is preferred (refer FIG. 6'O' system 510u; U.S. patent Ser. No. 10/113,534); with the top lines **457vax**' held in place by a motorized **49ax**' winching reel **52ax**' affixed abroad submersible vessel **230vax**. A closed loop, double lines system enables ease of access of said floating tidal turbines for maintenance checks; repair; etc. bottom loop of line may be held in place by pulley **48ax** system. Lines carried by winch-reel **52ax**' of UUV-**230vax**;

may be adjusted; slackened or tightened as required. Enabling said buoy **508ax** or ballast vessel **578ax**; including the floating tidal turbines **768v**; **768w**; **471vax**; to be lifted abroad a customized vessel **730**; specialized mother ship **741**; out-riggers **747**; flat-bed pontoons **734**; for checks and repair. Upon completion; released; re-submerged back into the sea again.

FIG. 10H illustrates a seabed **537ax** mounted bottom line reel **52ax**"; powered by a ram-water-turbine RWT-**71vax** comprising: tidal turbine **472ax** connected to gearbox **583ax**; winching mechanism **49ax**". This tidal turbine driven line reel **52ax**" provides an optional configuration wherein; said closed loop double lines system of FIG. 10G above may be superceded by means of a single line connected to two (twin) line reels **52ax**'; **52ax**"; system. Top end of line **457vax**' may be connected to a top line reel **52ax**' mounted on the body of submersible vehicle **230vax**. The bottom end of line **457vax**" maybe anchored to a bottom line-reel **52ax**" affixed to the seabed **537ax** and concrete pad **653**; driven by a RWT-**71vax**; a variant apparatus similar in concept to a Ram-Air-Turbine (RAT) **71ax**. The RWT-**71vax** transforms tidal flow into torque; which may be transmitted by gearbox **583ax**; to operably drive a driven unit comprising: winch **49ax**"; spool **52ax**" bearing line **457vax**".

FIG. 10I illustrates the side-sectional view of apparatus **835**; a variant tidal turbine system **471vax**; **617v**. A seabed based variant of floating sub-system **490ax** of FIG. 5C; device **835** may be affixed securely onto the seabed **537ax**. Wherein said apparatus comprising of multiple turbine units **472ax**; may be configured with counter rotating generation capabilities of present specification; with the generation components **474ax**; **476ax**; embedded in specialty moisture repellent materials; coated in water-proofed substances **806**. Wherein, specific turbines **472ax** may be configured with split functions to drive specific generation components comprising: rotor magnets **474ax**; rotor coils **476ax**. Tidal turbine system **835** may comprise of a linear configuration wherein said multiple turbines may be arranged in series, one after another. In the illustrated diagram, five turbines may be lined up in series; wherein, in a variant split-unit functionality and power generation concept of present invention; (for example: counting from left to right); turbine number one, three and five may be configured to drive individual rotor magnets **474ax** clockwise; independently of each other. While turbine number two and four may be combined and configured to drive the extended rotor coil **476ax** (integrated with the central shaft **581ax**) anti-clockwise. Wherein, said turbines one, three, five rotates in an opposite direction to turbines two and four. More turbines may similarly be configured in series; for example: 10 units; 15 units; etc. The power generation components may be supported by bearing boxes **586ax**; bearings **597ax** packing assembly; etc. To offset the drop in tidal flow rate; aft turbine units may be configured with longer and larger turbine blades **472ax**. Optionally, solid hoods or shrouds **615** may be used to divert tidal flow into said turbine blades. Said hoods may also be variably configured to produce the desired tidal flow to individual turbines; such that said tidal turbines produces the required torque configuration as per design specification. Concrete base **653** may be erected securely affixed to seabed **537ax** using piles **562ax**; drill strings **655**; drill casings **651**; (refer FIG. 3A to FIG. 3G). The metal base plate **836** of turbine system **835** may be affixed by means of specially configured drill strings **655** adapted for fitting with drill casings **651**. And locked securely in place. Removal may be effected by means of an extended drill string **655** from surface ship **741** to drill casing **651**. Unlocking the base

## 61

plate **836** from the drill casing **651**; lifting the entire apparatus **835** to surface for maintenance and repair. With drill string **655** acting as a super large sized screw driver.

FIG. **10J** illustrates an optional configuration wherein, said system **835** of FIG. **10I** may be configured with extended hoods **615**; solid shrouds **615**; for improved efficiency and productivity. Said hoods **615** may be configured with variable size; length; and angular inclination for enhanced performance; they may be constructed of solid; semi-solid; or pliable plastics, fabric materials; etc. Shrouds may be configured round; conical; square; rectangular in shape. And may be affixed into; or removed piece by piece; unit by unit from, the concrete base **653** and frame **836**; forming a fluid diversion mechanism around said turbines **471vax**; **617v**. At the same time solid shrouds **615** acts as machine guarding on said spinning turbine blades **472ax**, keeping out wildlife.

FIG. **11A** illustrates a fully manual system of deployment wherein a driven unit **55ax** may be connected to a drive unit **51ax**; including a retract line reel **R52ax** and winching motors **R49ax**. Two independent units may be placed side by side (looking from left to right, marked: port side; starboard side). The port side unit is shown in power run phase. While the starboard side unit is shown in retraction phase; being retrieved back to base; to the Start-Of-Run (SOR) point **16ax**. At the end of power generating run when tether line **50ax** had been depleted (designated run length used up); End-Of-Run (EOR) point **288ax**; the drive unit **51ax** must be retracted back in proximity to the driven unit **55ax**; by means of retract line **33ax**; retract line-reel **R52ax**; and winching motor **R49ax**. One unit (port side) on active service; one unit (starboard side) being retracted; then placed on standby. The two drive cum driven units **51ax**; **55ax**; located port; starboard; each taking turns to generate renewable electricity. Efficiency-wise, this may be less than desirable. This deficiency may be overcome and optimized by means of a variant system of FIG. **11B**.

FIG. **11B** illustrates a semi-automated variant system of FIG. **11A**; wherein, said driven unit **55ax** comprising of; a single generator **54ax** may be configured with twin sets of line reels **52ax**; clutch-gearbox **53ax**; **587ax**; winching motors **49ax**. One set on each side: port (indicated by letter "P") and starboard (indicated by letter "S") of generator **54ax** connected to a common shaft **581ax**; linked to two individual drone controlled drive units **51pax**; **51sax**. One drive unit **51pax** on power run; one drive unit **51sax** being retracted; then put on standby. Drive unit **51pax**; **51sax** may be integrated with a variant (shortened) drone body **199vax**; **201vax**; fitted with winch **59ax** for retracting a variant retract line **33vax** (refer: FIG. **11A** to FIG. **11J**); of parent U.S. Pat. No. 9,447,775); joined to tether line **50ax** at point **229ax**. At the end of the power generating run, the drive unit **51ax** must be depowered; and then retracted back to base. Computerized control systems used for execution of said power generation system; includes activation means for triggering said start-of-run (SOR); end-of-run (EOR) depowering; retraction phases; in the drone units; etc. Replenishment of utilities comprising: batteries; compressed air; hydrogen, ethanol (used by fuel-cells); functional checks; etc. may be done during stand-by phase. Wire-line; wireless means of transmission for command and control signals may be employed between the command-control-center and drones. Such a configuration enables generator **54ax** to be operated continuously; alternately powered by means of the port or starboard side based drone-controlled drive units **51pax**; **51sax** connected to: line reels **52ax**; clutch-gearbox **53ax**; **587ax**; and winching motors **49ax**.

## 62

FIG. **11C** illustrates a variant structural configuration of FIG. **11B** wherein, a counter-rotational driven unit **55ax** may be configured comprising: one generator **585ax**; **590ax**; **777**; four independent sets of: line reels **52ax**; clutch-gearbox **587ax**; winching motors **49ax**; connected by means of two split-unit shaft portions **581pax**; **581sax**; (refer system 590h, FIG. 7H; U.S. patent Ser. No. 10/113,534). Said line-reels **52ax** may selectively be engaged or disengaged by means of clutch-gearbox **587ax** to shaft portions **581pax**; **581sax**. Two sets configured on each side: port (P'; P'') and starboard (S'; S''); connected to four individual drive units **51pax'**; **51pax''**; **51sax'**; **51sax''**. Two drive units (**51pax'**; **51sax'**) on active service; with two drive units being retracted/and put on standby (**51pax''**; **51sax''**); at any one time. The port side line-reels **52pax'**; **52pax''**; may be configured to drive the rotor coils **474ax**; while starboard side line-reels **52sax'**; **52sax''**; may be configured to drive the rotor magnets **476ax**; of the counter-rotation generator.

Optionally, a single common shaft **581ax** may be used to link up all of the line-reels **52ax** together; operably connected by means of clutch-gearboxes **587ax**. And by means of a planetary gear apparatus **830** configured into the torque transmission system (shaft **581ax**); half of the original torque (example: clockwise rotation) derived from drive units **51pax'**; **51sax'** may be transformed into an opposite direction (example: anti-clockwise rotation) of movement. These two opposing torque may be configured to power any one generating component: rotor coil **474ax**; rotor magnet **476ax**; of counter-rotating generator **585ax**; **590ax**; **777v**. The percentage of torque transformation from one direction of rotation into another direction of rotation may be configured to be varied; such as proportionate: 50%: 50%; non-proportionate: 40%: 60%; or 30%: 70%; etc. by means of variations in the size(s) of gears configured into apparatus **830**. An optimal conversion amount may be derived by means of testing; and applied to the power generation system.

FIG. **11D** to FIG. **11G** illustrates the integration of turbine generators **835** of FIG. **10I** and FIG. **10J**; including apparatus **500aax**; **500vax**; **471ax**; etc. with floating-submersible vessels which provide means of: protection; carriage and transportation; a structure for mounting shrouds; hoods; mechanical supporting systems; etc. Enabling said turbines and turbine generators of present invention to be deployed from: the top to the bottom of the vertical water column. From arrays of floating turbines mounted beneath surface platforms such as: ships **741**; outriggers **747**; pontoons **840**; ballast tanks **578ax**; buoys **508ax** (FIG. **11D**). To arrays of floating turbines suspended in the middle of the water column (FIG. **11E**). To seabed **537ax** mounted bottoms turbines **835**; **500vax**; (FIG. **11F** to FIG. **11G**). Counter-rotating turbine-generator **835**; including unit **500aax**; **500vax**; **471ax**; etc. may also be configured in between the bodies of two floating pontoons **840**; one on top **840t**, one at the bottom **840b**. Said twin pontoons **840t**; **840b**; may be configured with dual capabilities: functioning both as a surface vessel; and as a submersible vessel. Capable of operating as a submarine; staying submerged and suspended in the middle of the vertical water column for prolonged periods of time. Apparatus **840** may be configured with buoyancy control sub-system **686**; ballast tanks **578**; compressed air cylinders **203ax**; floatation chambers **837**; compressors **838**; etc. Connected by means of structural beams **839**; carrying a turbine-generator **835** in its belly; said dual pontoons **840** may be configured to change its utility purpose from: (a) a surface floating vessel **840a** of FIG. **11D**; to (b) an under-water vehicle **840b** submerged beneath the

surface; suspended in the middle of the water column like a submarine of FIG. 11E; to (c) a sea bottom vessel **840c** anchored by means of legs **841** to mounting apparatus configured into the seabed **537ax** of FIG. 11F and FIG. 11G. Such optional means of utility enables the deployment of turbine-generators from the top of the water column (water surface **621**); to the middle of the water column; to the bottom of the seabed **537ax**. And whenever required, to surface for periodic maintenance checks; repairs; etc. One side of the pontoons may optionally be configured with a control room and bridge **842** for manned operation of machineries. Access to the bridge by personnel may be made by means of a personal submersible vehicle PSV-**230ax**; via an air-lock tunnel configured into structure **842**. The entire apparatus may be anchored to the seabed **537ax** by means of lines **295ax**.

Turbine-generator **835**; **500vax**; **500aax**; **471ax**; etc. may be configured as a modular unit; the walls or doors **843** forming a six sided protective structural enclosure around apparatus **835**. Which is concealed in between the bodies of the top and bottom pontoon **840t**; **840b**; while the 4 sides surrounding the turbine-generators comprising: fore and aft; port and starboard sides may be configured with sliding doors **843** operated by mechanical means. Normally the doors remain closed and the shrouds retracted when not in use. But open during operation. Fore, port and starboard doors may be configured and used as solid shrouds **615**; pliable hoods **40ax**; enabling tidal flow to be collected and channeled into the turbine blades. The bodies of pontoon **840** may be used as supporting structures for mounting equipment; deploying and retracting shrouds **615**; fabric bags **30ax**; **40ax**.

FIG. 11D illustrates the side view of a surface based floating apparatus **840a**; with a turbine-generator **835** inside its belly. A flexibly extendable and retractable shroud **615** may be deployed to collect and channel tidal flow to apparatus **835**. Not shown are the sliding side-doors **843** which may be flipped outward, acting as shrouds entrapping; diverting tidal current flow to apparatus **835**; (refer FIG. 10J for an extended shroud **615**). Apparatus **840a** may be anchored by means of securing lines **295ax** to the seabed **537ax**.

FIG. 11E illustrates the side view of a submerged variant of the surface floating apparatus **840** of FIG. 11D. A neutral buoyancy apparatus **840b** suspended in the middle of the water column; beneath the surface apparatus **840a** of FIG. 11D; but above the sea bottom apparatus **840c** affixed by means of legs **841** to the seabed **537ax** of FIG. 11F and FIG. 11G. As illustrated in FIG. 11E, the bodies of said top and bottom pontoon **840t**; **840b**; may be flipped over from top to bottom; or vice-versa. In its belly may be configured a plurality of 3 units of turbine-generators **500aax**; **500vax**; **471ax**. Which maybe flipped into a lying down position when not in use. Or, flipped upward into a vertical, power generating position by means of pneumatic arms; or hydraulic arms **807**; **808**. Fabric shroud **40ax** may be deployed or retracted by means of supporting apparatus anchored to the pontoon's body. Shroud **40ax** may be secured using bridle lines **21ax**.

FIG. 11F illustrates a perspective view of a sea bottom based apparatus **840c** flexibly affixed to anchoring apparatus built into the seabed **537ax**. Apparatus **840c** may be configured to anchor itself by means of appendages **841** to seabed based anchoring apparatus; and to dislodge or release itself. It may be configured to vary its buoyancy to submerge; and to surface. Fore doors and sliding doors **843** at the port and starboard side may be flipped open to channel

tidal flow into the turbine blades of turbine generator **835**. Or closed when not in active service. Fore doors may also be configured to be hydro-dynamic in shape; like the pointed bow doors of FIG. 11G. Which maybe swung open widely to aspirate tidal flow. FIG. 11G illustrates a plan view of a variant configuration of FIG. 11F; wherein, dual pontoons **840p** and **840s** may be configured side by side; located port and starboard. Just like an apparatus **840a** flipped onto its side. Fore and side doors located on top may operably be opened or closed.

FIG. 11H and FIG. 11I illustrates the integration of turbine-generator **500eax** with the body **201ax** of HUV-**200vax**. FIG. 11H illustrates a variant windmill like counter-rotating turbine-generator **500eax** (refer FIG. 5a to FIG. 5j; U.S. patent Ser. No. 10/113,534). Turbine generator **500eax** exhibits; and combined both the shrouded (inner turbine blades **492ax** surrounded by generating elements **493ax**; **494ax**); and the open flow concept (outer turbine blades **471ax**) of an energy conversion apparatus. Apparatus **500eax** may be used individually; independently by itself. Alone. Apparatus **500eax** may also be integrated into; to work with other components and disclosures of present invention as illustrated in variant apparatus **800k**, directly mounted on the body **201ax** of FIG. 11I. The inner ring of turbine blades **492ax** may be configured to drive the rotor-magnets ring **494ax**; while the outer ring of turbine blades (**471ax**) may be configured to drive the rotor-coil ring **493ax**. The open hole in the middle may be configured to drive a generator mounted inside the body **201ax** of HUV-**200vax**.

FIG. 11I illustrates a variant apparatus **800k** (refer: apparatus **800f**; **800j** of FIG. 8P; FIG. 9D). Wherein the body **201ax** of a HUV-**200vax** apparatus maybe configured with a plurality of counter-rotating turbine-generators **471ax**; **500eax**; directed affixed onto its body **201vax**. Generating power by means of: rotor coils **474ax** and rotor magnets **476ax**; directly mounted inside its body **201vax**. Turbine-generator **471ax** may be configured to drive the rotor coil **474ax**; while the inner blades ring **492ax** of the twin turbine units **500eax** may be configured to drive the rotor magnets **476ax**. Or, vice-versa. Floating submarine body **201vax** may be anchored to the seabed **537ax** by means of securing lines **295ax**. At the same time, the outer ring of multiple turbine blades **471ax** may be configured to drive the rotor magnet ring **494ax** clockwise. While the inner ring of multiple turbine blades **492ax** may be configured to move and drive the rotor coil ring **493ax** anti-clockwise. Or, vice-versa. The generating elements may be supported by bearing boxes **586ax**; packing assembly; etc.

Mission—Vision Statement: To reduce; eliminate Global Warming; to save our spaceship—Planet Earth from the dangerous effects of Global Climate Change! The use of drones to serve humanity! To produce clean energy; to preserve clean air and clean water for all of us! We must always remember this; that we only have:

One race—Humanity! One planet—Earth! One common Destiny!

We must all work hard to preserve; not destroy, our one and only “live support system”—Earth's biosphere! For in the fate of mother Earth; and in our own hands, lies our common destiny—for all things living on this planet; and future generations of—plants; animals; humans. It is our common duty and responsibility to do our part: innovators, entrepreneurs, financiers, governments and NGOs, etc. To Save The World, Our World! “Look high, look far. Our aim the sky, our goal the stars!” To an inventor the sky's the limit.

65

To Quote: "I don't believe in climate change. Belief doesn't come into it; scientific verification does. Gravity doesn't care whether you believe in it or not. But if you step off a cliff, you're going to go down."—Dr Katherine Hayhoe, (Climate Scientist, Texas Tech University, USA)

Finally, it is to be understood that various alterations, modifications and/or additions may be introduced into the constructions and arrangements of parts previously described without departing from the spirit or ambit of the invention.

The invention claimed is:

1. A drone power-generator apparatus (800b) for the generation of renewable energy comprising:

a counter rotating wind turbine assembly (500vax) integrated with a drone unit and forming a drone body (77ax), the counter rotating wind turbine assembly comprising two separate turbine units wherein one turbine unit rotates clockwise and the other turbine unit rotates counter-clockwise to generate electricity and wherein each separate turbine unit is comprised of a

66

turbine blade embedded with (492ax) dual rings of rotor coils (474ax) and rotor magnets (476ax); and a plurality of propulsion systems (70ax);  
 a surface based sub-station (622);  
 a conductive tether line (50ax) configured to connect the drone body to the surface based sub-station;  
 a plurality of bridle lines (21ax) connecting various points of the drone body to the conductive tether line wherein the length of the bridle lines are controlled by a winching system mounted inside the drone body;  
 wherein the apparatus is configured to vary the length of the bridle lines to adjust the position of the drone body relative to a wind direction and maintain a stable position at an inclined angle such that the counter rotating wind turbine assembly may convert wind energy into electrical energy; and  
 wherein said conductive tether line is further configured to transfer power to and from the drone body to deliver power from the wind turbine or to deliver power to the plurality of propulsion systems.

\* \* \* \* \*